

THIRD ANGLE PROJECTION		REVISIONS			
	REV	DESCRIPTION	ECO NO	DATE	CHG/CHK
	01	RELEASE TO PRODUCTION.	13791	08/10/16	RMC/BVT

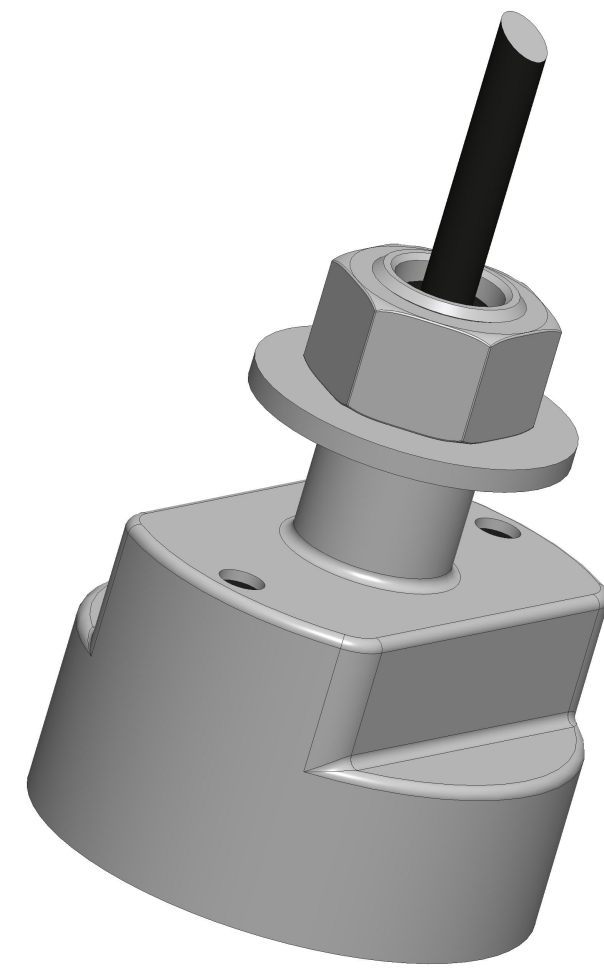
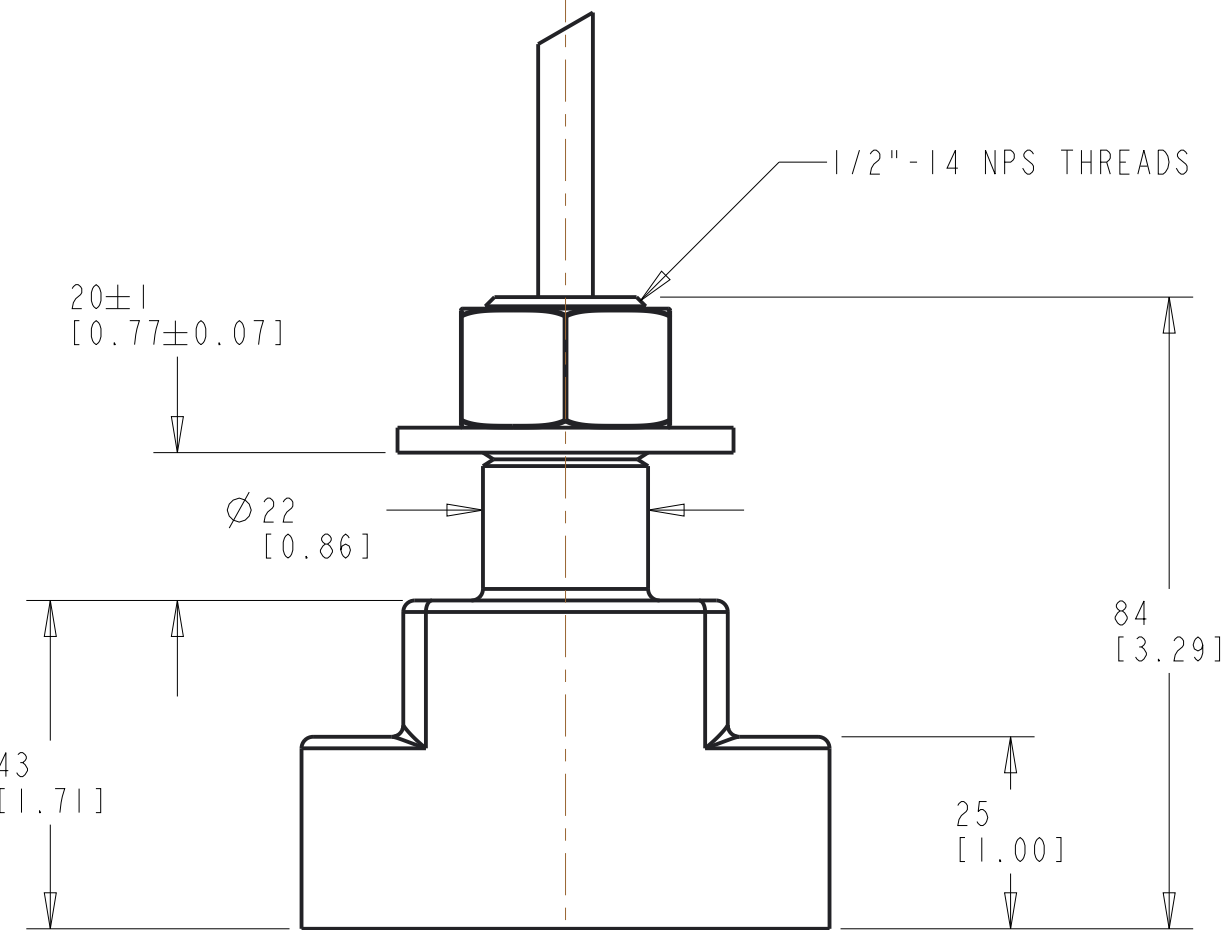
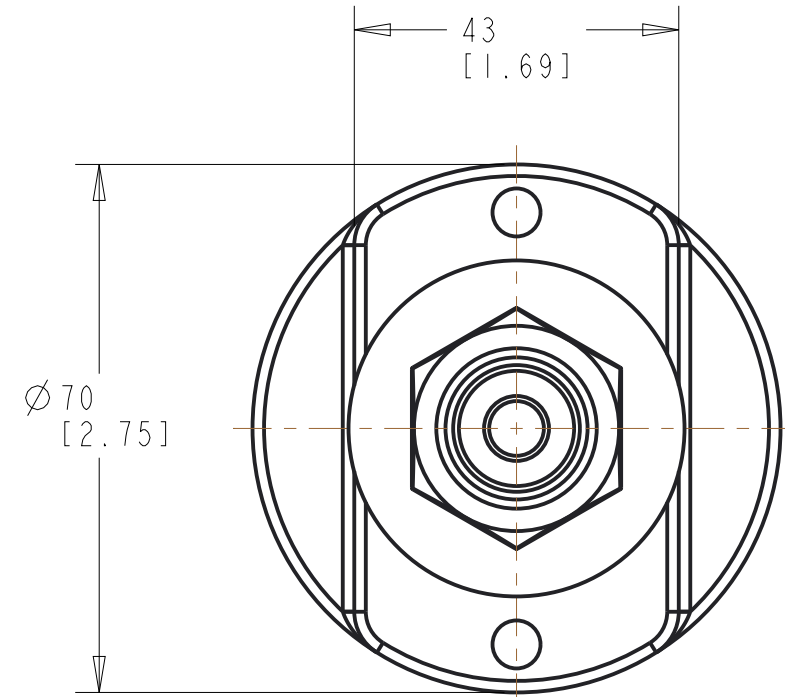

UNLESS OTHERWISE SPECIFIED DIMENSIONS ARE IN INCHES TOLERANCES ON 2 PL DECIMALS: ±0.02 3 PL DECIMALS: ±0.005 ANGLES: ±1/2° FRACTIONS: ±1/16 MIN SURFACE FINISH: √250	SIGNATURE	DATE	<b>AIRMAR</b> AIRMAR TECHNOLOGY CORPORATION 35 MEADOWBROOK DR MILFORD NH 03055-4613 USA TEL: 603-673-9570 FAX: 603-673-4624
	DRAWN: A. BAIRAMOV	06/18/06	
	REDRAWN: R. CULLEN	07/14/16	
MATERIAL		TITLE	
304 OR 316 STAINLESS STEEL		OUTLINE DRAWING SS510	
SIZE	SCALE: FULL	NUMBER	
B	SHEET 1 OF 1	92-225-01 REV 01	