

Model C12-17

Combustible Gas

Transmitter

Home Office

Analytical Technology, Inc.
6 Iron Bridge Drive
Collegeville, PA 19426
Ph: (800) 959-0299
(610) 917-0991
Fax: (610) 917-0992
Email: sales@analyticaltechnology.com

European Office

ATI (UK) Limited
33 Bank Chambers, 33 Stamford St.
Mossley, Ashton-u-Lyne OL50LL
Ph: 0800-018-4020
+ 44 (0) 1457 832800
Fax: + 44 (0) 1457 839500
Email: sales@atiuk.com

PRODUCT WARRANTY

Analytical Technology, Inc. (Manufacturer) warrants to the Customer that if any part(s) of the Manufacturer's products proves to be defective in materials or workmanship within the earlier of 18 months of the date of shipment or 12 months of the date of start-up, such defective parts will be repaired or replaced free of charge. Inspection and repairs to products thought to be defective within the warranty period will be completed at the Manufacturer's facilities in Collegeville, PA. Products on which warranty repairs are required shall be shipped freight prepaid to the Manufacturer. The product(s) will be returned freight prepaid and allowed if it is determined by the manufacturer that the part(s) failed due to defective materials or workmanship.

This warranty does not cover consumable items, batteries, or wear items subject to periodic replacement including lamps and fuses.

Gas sensors, except oxygen sensors, are covered by this warranty, but are subject to inspection for evidence of extended exposure to excessive gas concentrations. Should inspection indicate that sensors have been expended rather than failed prematurely, the warranty shall not apply.

The Manufacturer assumes no liability for consequential damages of any kind, and the buyer by acceptance of this equipment will assume all liability for the consequences of its use or misuse by the Customer, his employees, or others. A defect within the meaning of this warranty is any part of any piece of a Manufacturer's product which shall, when such part is capable of being renewed, repaired, or replaced, operate to condemn such piece of equipment.

This warranty is in lieu of all other warranties (including without limiting the generality of the foregoing warranties of merchantability and fitness for a particular purpose), guarantees, obligations or liabilities expressed or implied by the Manufacturer or its representatives and by statute or rule of law.

This warranty is void if the Manufacturer's product(s) has been subject to misuse or abuse, or has not been operated or stored in accordance with instructions, or if the serial number has been removed.

Analytical Technology, Inc. makes no other warranty expressed or implied except as stated above.

TABLE OF CONTENTS

INTRODUCTION.....	4
Figure 1: Typical System Diagram, (ATI-0145).....	4
SPECIFICATIONS	5
INSTALLATION.....	6
Figure 2: Combustible Gas Sensor/Transmitter Dimensions (ATI-046)	6
SENSOR LOCATION	7
INTERFERENCES	7
ELECTRICAL CONNECTIONS - TRANSMITTER	8
Figure 3: Transmitter customer connections (ATI-0237)	8
ELECTRICAL CONNECTIONS - SENSOR.....	9
Figure 4: Sensor Connections to Transmitter (ATI-0144).....	9
DUAL CONDULET SYSTEM	10
Figure 5: Dual Condulet Connections (ATI-0579).....	10
Figure 6: Dual Condulet Typical Installation.....	10
OPERATION	11
CALIBRATION.....	11
Figure 7: Sensor/Transmitter Connectors, Controls and Test Points (ATI-0143)	12
TRANSMITTER ZERO	12
TRANSMITTER SPAN.....	13
TRANSMITTER FAULT INDICATION.....	13
CALIBRATION FOR OTHER COMBUSTIBLE GASES	14
SENSOR RESPONSE TEST	15
SENSOR REPLACEMENT	15
DISPLAY & RELAY OPTION	16
Figure 8 – Enclosure with Display Dimensional Drawing (ATI-0569).....	16
Figure 9 – Transmitter with Display Customer Connections (ATI-0570)	17
ALARM ADJUSTMENT	18
TROUBLE FUNCTION	18
C12-17 TRANSMITTER W/O DISPLAY SPARE PARTS LIST	19
Figure 10 – Standard Combustible Transmitter Exploded View (ATI-0146)	19
C12-17 TRANSMITTER WITH DISPLAY SPARE PARTS LIST.....	20
Figure 11 – Standard Combustible Transmitter Exploded View (ATI-0571)	20

INTRODUCTION

Series C12-17 sensor/transmitters combine catalytic bead type gas sensors and an electronic amplifier that transmits gas concentration using a standard 4-20 mA signal. They are designed to continuously monitor combustible gas concentrations in ambient air near process tanks or piping, or in enclosed spaces where combustible gases may accumulate. C12-17 transmitters are available in two versions, one containing an integral display and single alarm relay, and a second that is a simple "blind transmitter" with no display or alarm functions.

Gas sensors are housed in a corrosion resistant stainless steel shell with a sintered metal flame arrestor isolating the sensing elements from the ambient air. A 3/4" NPT thread at the back of the sensor mates with the threaded entry on the explosion-proof transmitter enclosure. Series C12-17 sensor transmitters are designed for use in Class 1, Division 1, Groups A, B, C, or D locations.

A typical installation for the C12-17 is shown in Figure 1 below.

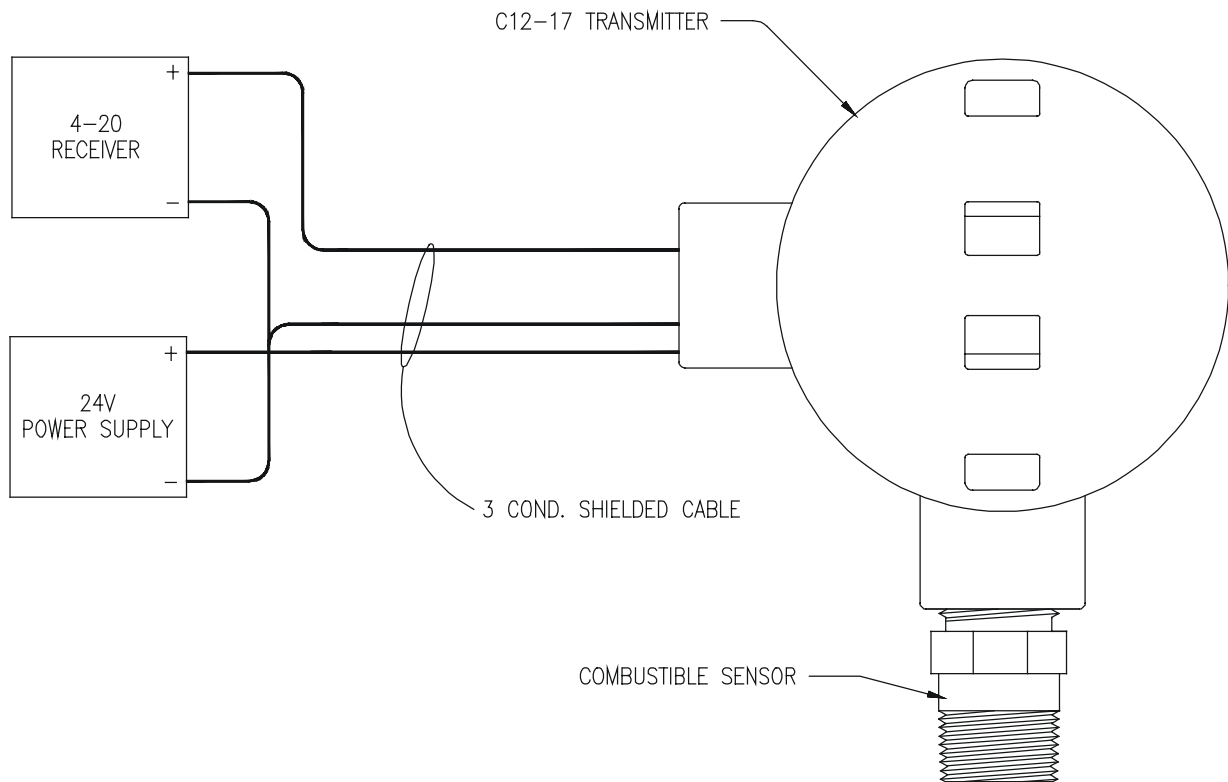

Figure 1: Typical System Diagram, (ATI-0145)



SPECIFICATIONS

Range:	0-100% LEL (Lower Explosive Limit) Standard 0-50% LEL Optional
Response Time (T90)	10 Seconds
Sensitivity:	1% LEL
Zero Drift:	< 2%/Month
Power:	10-28 VDC, 24 VDC at 100mA nominal
Output:	4-20 mA DC, 200 ohms maximum load at 12 VDC 800 ohms maximum load at 24 VDC 1000 ohms maximum load at 28 VDC
Display:	Optional 2 ½ digit LCD
Alarm:	Single setpoint or Trouble with SPDT, 1A, 125VAC; 1A, 30VDC alarm relay
Temperature Limits:	-40° to + 70° C.
Sensor Materials:	316 Stainless Steel
Enclosure (Blind):	Galvanized Cast Iron for blind transmitter
Area Classification:	NEC Class 1, Division 1, Groups B, C, & D
Enclosure (for Display):	Extruded Aluminum with glass window
Area Classification:	NEC Class 1, Division 1, Groups A, B, C, & D
Connections:	3 wire, 20 AWG, 500 feet max. (150 m.)
Sensor Cable Length:	Maximum 50 feet for separation between sensor and transmitter
Weight:	3 lbs. (1.4 Kg.)

INSTALLATION

Combustible gas sensor/transmitters are explosion-proof assemblies that are normally mounted directly to suitable explosion-proof conduit. To maintain the explosion-proof integrity of the transmitter, a suitable cable entry seal must be used in accordance with the applicable electrical code. Sensor/transmitters should be mounted with the sensor facing down as shown in Figure 2.

NOTE: Gas sensors are shipped with a protective plastic cap over the end. This cap should be left in place to avoid damage to the sensor during installation. If the detection system is to be activated within a few days of installation, the cap should be removed when installation is complete. Otherwise, leave the cap in place until the system is to be placed in service. **Be sure to leave the protective cap on the sensor if painting is to be done in the area of the sensor.**

Series C12-17 transmitters require connection to a DC power supply and connection of the 4-20 mA output to a receiving device such as a computer, recorder, or data logger. A 3-conductor cable may be used for this purpose and is made at the terminals marked TB1 on Figure 3. Transmitters with the optional display and relay may use a 2-wire connection if only the local relay is to be used. If the 4-20 mA output is to be used, a 3-wire connection is needed.

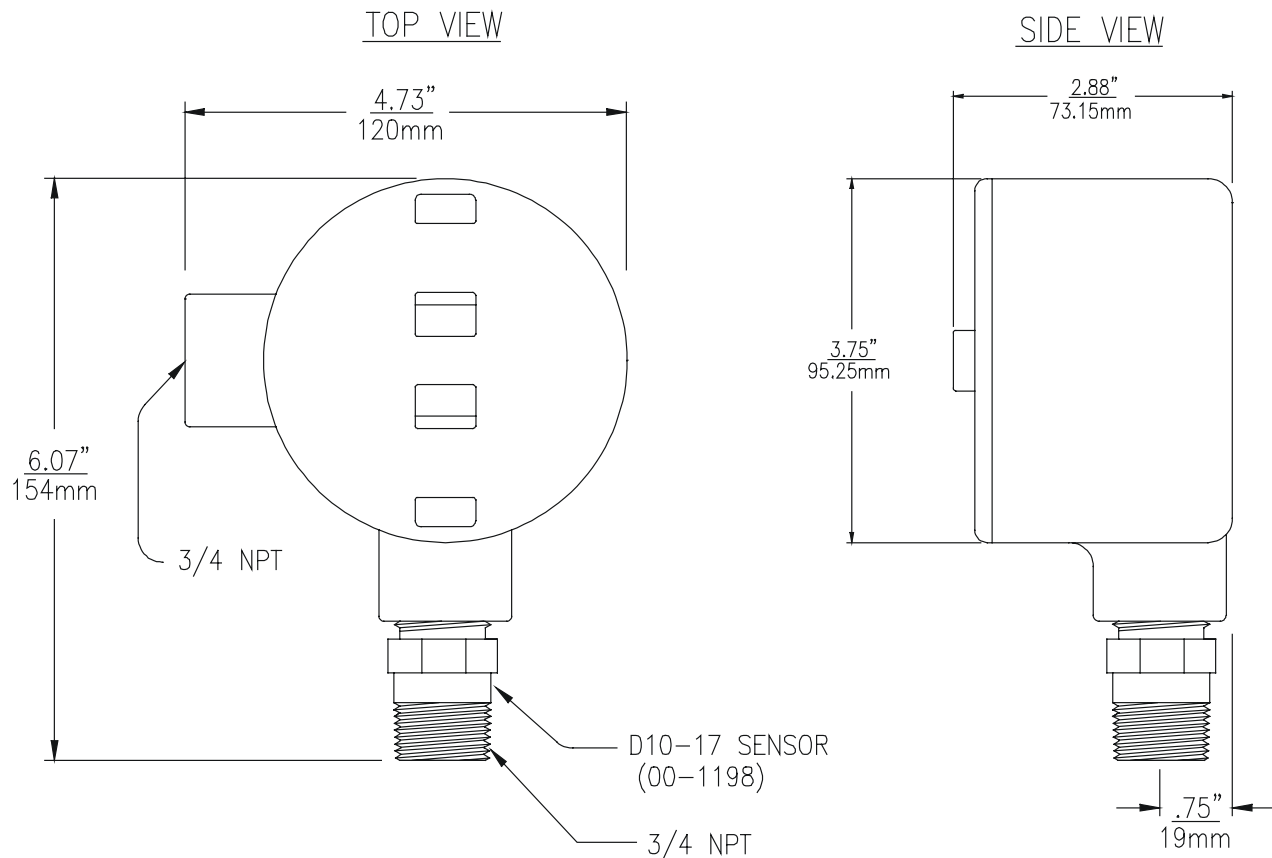

Figure 2: Combustible Gas Sensor/Transmitter Dimensions (ATI-046)



SENSOR LOCATION

Combustible gas sensors are used to detect a variety of gases or vapors. The proper sensor location will depend on what type of gas is expected. For gases that are lighter than air, such as methane, sensors should be located near the ceiling. For gases that are heavier than air, such as butane, sensors should be mounted near the floor. If the gas or vapor has a density near that of air, locate the sensor about 5 feet off the floor in enclosed areas. Gas sensors mounted outdoors should be located near anticipated leak sources (valves, flanges, compressors, etc.) and the location will depend on normal wind patterns and anticipated employee activity areas.

The following are a few common combustible gases, along with their relative density (air = 1.00). Densities less than one indicate gases that are lighter than air while those with densities greater than one are heavier than air. Combustible vapors from most solvents, such as Benzene, n-Hexane, Methanol, Ethanol, and MEK, are heavier than air and will tend to accumulate near the floor in enclosed spaces with little air movement.

Methane	0.55
Butane	2.11
Propane	1.55
Hydrogen	0.07
Ammonia	0.60

INTERFERENCES

Combustible gas sensors contain two heated elements. One of these elements is active, and will allow combustible gases or vapors to burn on its catalytic surface. The other is passive, and does not react to gases. These two elements form two legs of a Wheatstone bridge measuring circuit. When combustible gas contacts the sensor, the active element burns this gas and the temperature of this element increases, changing its resistance. The transmitter measures the imbalance in the bridge circuit and transmits the data to the receiver for display and alarming purposes.

Combustible sensors are adversely affected by a few compounds that may be present in a given application. Probably the worst of these are silicone vapors from silicon based lubricants or sealants. High silicon vapor concentrations can cause complete loss of sensitivity in as little as a few hours. These sensors should not be used where silicon vapors are normally present, and sensors should be protected from these vapors if such compounds are in use temporarily.

Lead compounds and high levels of hydrogen sulfide can also cause degradation of combustible sensors. While lead vapors are not commonly encountered, they can also cause complete sensor failure if encountered. Hydrogen sulfide will cause reduced sensitivity over the first few weeks of exposure, but then will level out. The effect of hydrogen sulfide can normally be compensated for by re-calibration after the first few weeks of use.

ELECTRICAL CONNECTIONS - TRANSMITTER

External connections to the C12-17 transmitter can be made using 3 conductor cable. A 3-conductor cable uses a single conductor for the common of both the power supply and the output signal. Figure 3 shows typical connections to a power supply and a panel indicator running off the 4-20 mA signal from the C12-17 transmitter.

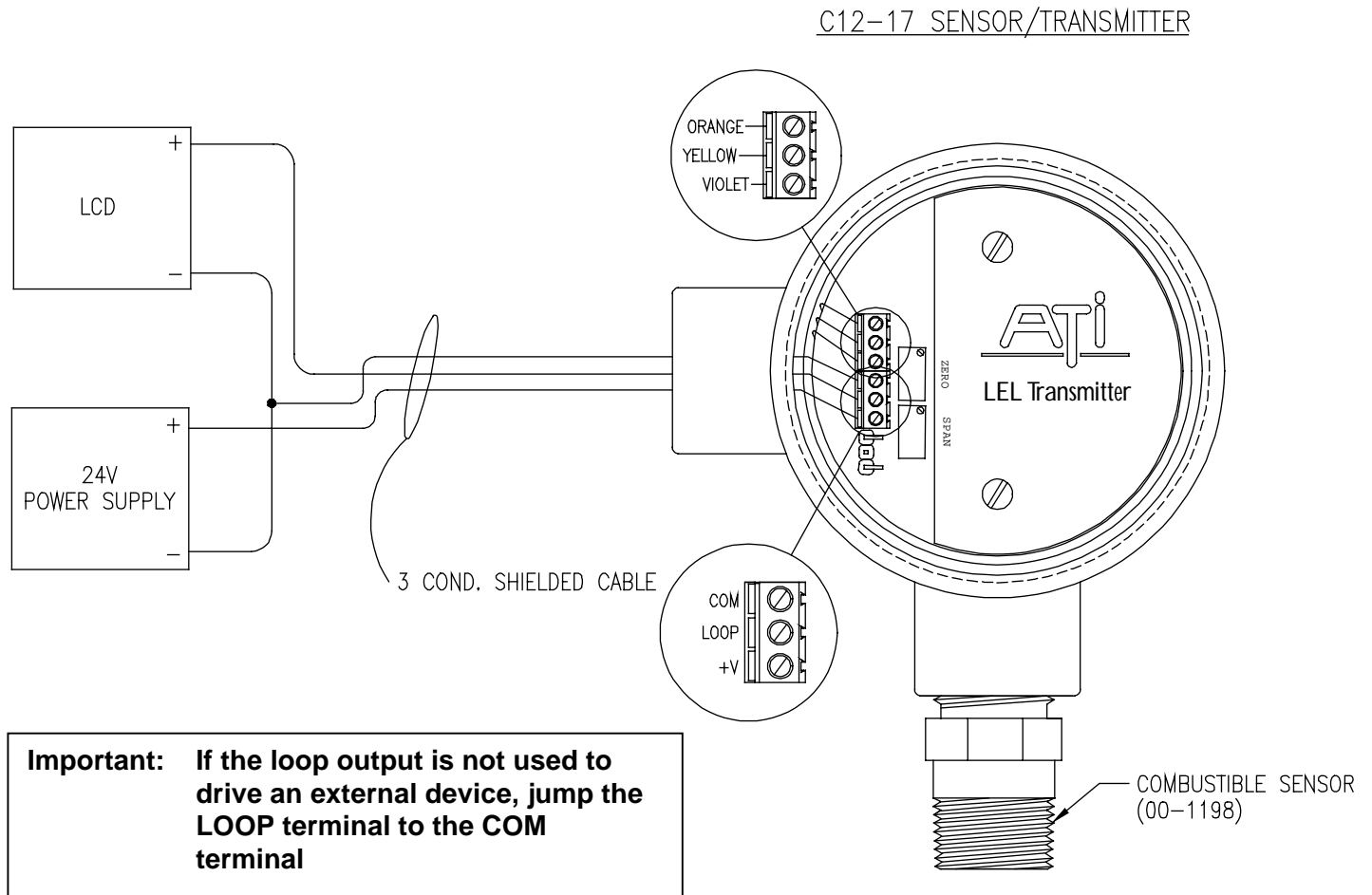

Figure 3: Transmitter customer connections (ATI-0237)

ELECTRICAL CONNECTIONS - SENSOR

Standard transmitters supplied with the sensor close coupled to the transmitter enclosure are factory wired as shown below. However, sensors can be supplied with up to 25 feet of cable for remote mounting. The wiring diagram for the extended cable version is also shown below. Extended cables should always be installed in suitable explosion-proof flexible conduit where required by the electrical code.

STANDARD SENSOREXTENDED CABLE SENSOR

Figure 4: Sensor Connections to Transmitter (ATI-0144)

DUAL CONDULET SYSTEM

For some indoor applications, it is more convenient to mount the sensor toward the ceiling of the room while keeping the transmitter electronics down at a convenient elevation for making calibration adjustments. ATI's dual condulet system is designed for this purpose, and the interconnecting wiring is shown below. A special remote calibration adapter can be used with this system to allow gas to be fed from a point near the transmitter as shown in Figure 6.

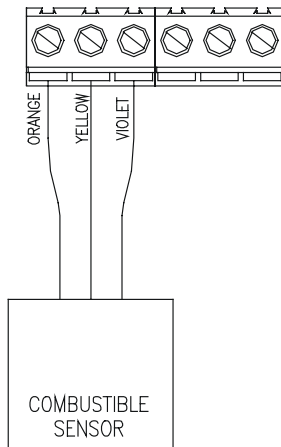
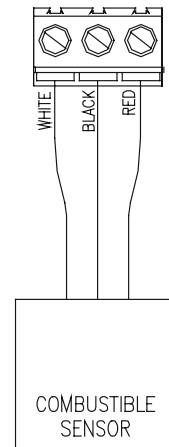
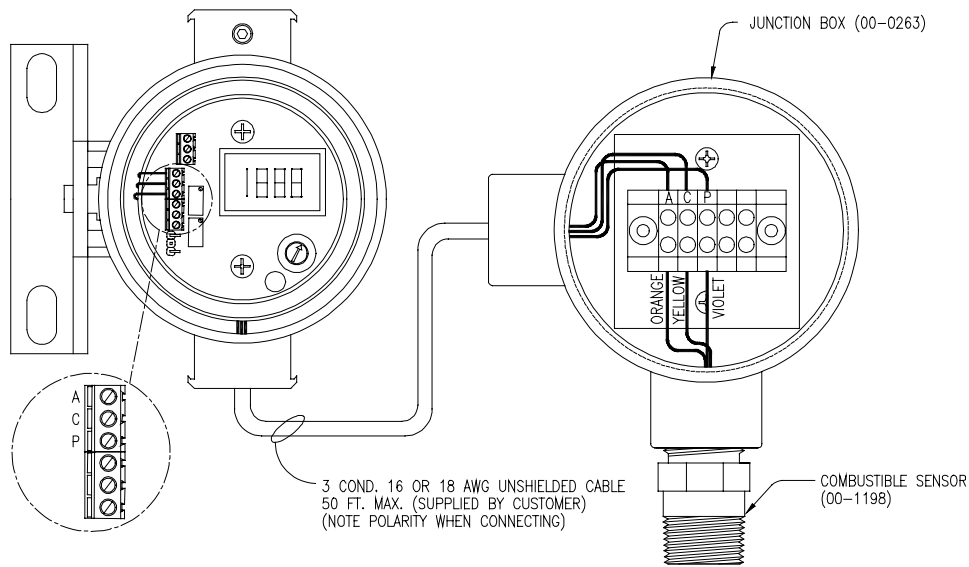

Figure 5: Dual Condulet Connections (ATI-0579)

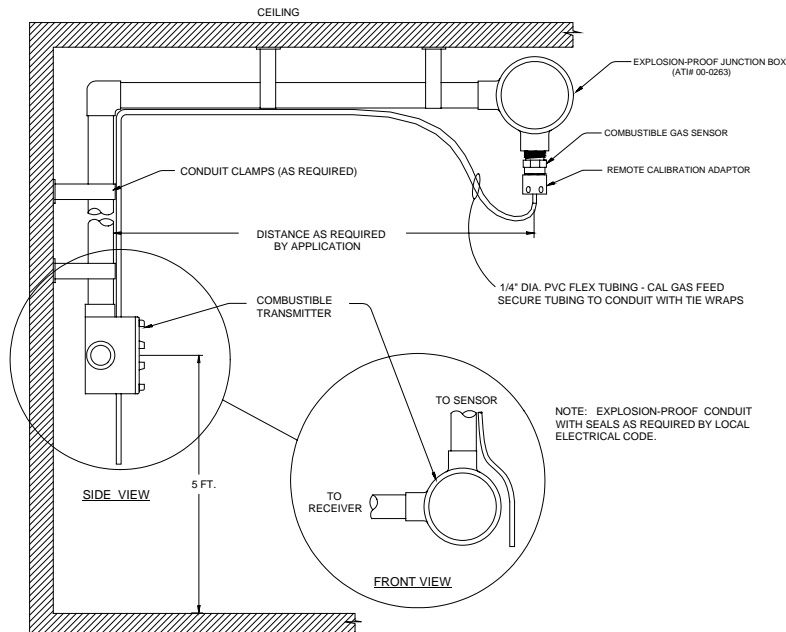

Figure 6: Dual Condulet Typical Installation

OPERATION

Once installation is complete, the C12-17 combustible gas transmitter is ready for operation. After verifying that electrical connections have been made properly, put the transmitter into operation by simply applying DC power. As soon as power is applied, the unit will begin to stabilize. Once stabilized, alarm system inhibit can be turned off, and the system will be in normal operation.

Note: The output of the transmitter will go to a high value when power is first applied. Alarm devices should be inhibited at this time so that alarm systems are not activated. The output will stabilize at 4 mA within about 10 minutes.

CALIBRATION

Combustible gas sensor/transmitters are factory calibrated for a standard range of 0-100% LEL Methane, using methane gas as the calibration standard. However, combustible gas sensors do not respond exactly the same to every combustible gas, and the percent of each gas that represents 100% LEL also differs for each gas. While methane gas standards can always be used for calibration, the value that the transmitter is adjusted to will vary depending on what type of gas the system is meant to detect.

Calibration of a combustible gas sensor/transmitter requires a digital voltmeter (DVM), a source of calibration gas, and a calibration adapter for the sensor. Calibration gas can be obtained in convenient disposable cylinders from specialty gas suppliers such as Scott Specialty Gases, Alphagaz, or Matheson Gas Products. Complete calibration kits may also be purchased from ATI. These kits contain one methane gas standard (1% methane in air, which is 20% LEL) in a disposable cylinder, a bottle of zero air, a cylinder regulator, and a calibration adapter.

Prior to calibration, remove the cover from the sensor/transmitter enclosure and connect a DVM to the test points (TP) shown in Figure 7. If the receiver for the system is near enough to easily see, you may use the digital display on the receiver instead of a DVM on the test points. The test points will provide a 40-200 mv. signal proportional to transmitter range. For a standard 0-100% LEL unit, 0% is 40 mv. and 100% is 200 mv.

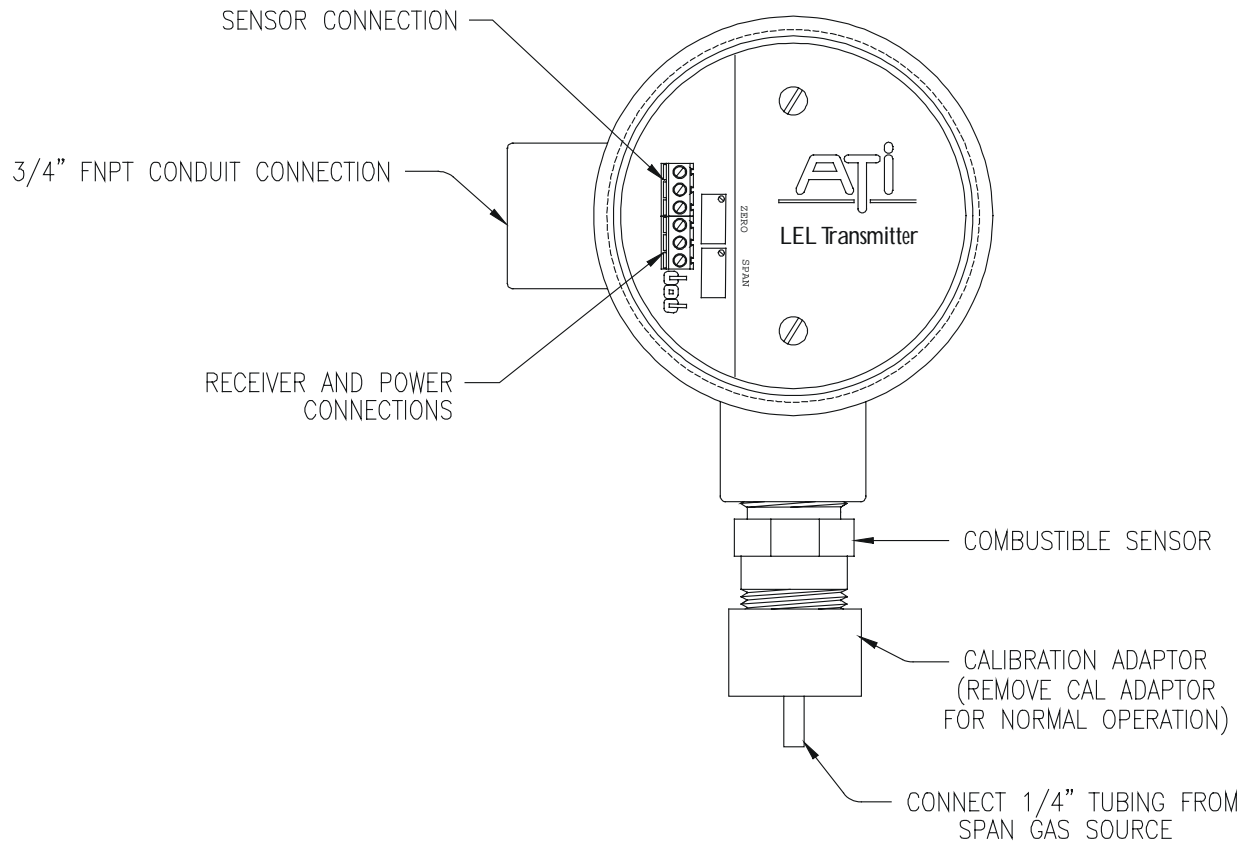

Figure 7: Sensor/Transmitter Connectors, Controls and Test Points (ATI-0143)

TRANSMITTER ZERO

The transmitter zero is adjusted with the sensor exposed to air that contains no combustible gas. Generally, the easiest method of zeroing the transmitter is to make the adjustment when you know that the area is free of combustibles. Because it is normally necessary to check the area with a portable combustible detector prior to removing the cover from the transmitter, the absence of an combustible gases or vapors can be verified fairly easily.

The transmitter can also be set to zero using "zero air" available in cylinders. Zero air cylinders and regulators are available from ATI or from specialty gas suppliers. Connect the zero air cylinder to the calibration adaptor and adjust gas flow to 500 cc/min. When the DVM stabilizes near 40mV, adjust the zero potentiometer until the DVM reads 40 ± 0.5 mv.

NOTE: If using the ATI receiver display when adjusting the transmitter zero, place the receiver in the "Inhibit" mode. When in the inhibit mode, the blanking around zero is disabled so that the zero can be set accurately.

TRANSMITTER SPAN

The span setting for a combustible gas sensor/transmitter will depend on the gas or vapor for which the unit will be mainly used. To calibrate the system for applications where methane in the main combustible to be expected, connect tubing from your span gas cylinder (1% Methane) to the calibration adapter inlet. Turn on the gas flow and adjust to approximately 500 cc/min. (ATI calibration kits contain fixed flow regulators that automatically provide 500 cc/min. flow). The reading on the DVM attached to the transmitter test points will immediately start to increase. Allow the gas to flow to the sensor for 2-3 minutes and observe the reading on the DVM. The reading should be relatively stable ± 0.5 mv. Use the span potentiometer to adjust the DVM to 72 mv. This adjustment assumes the use of 1% methane gas standards, which are the equivalent of 20% LEL. If using another methane concentration, calculate the voltage setting as follows: (v/o = Volume Percent)

$$V = 40 \text{ mV} + [160 \text{ mV} \times (\text{Span Gas Concentration in } \text{v/o} \div 5 \text{ v/o})]$$

As an example, if your span gas cylinder is marked with a concentration of 2.5% Methane, the calculation would be:

$$V = 40 \text{ mV} + [160 \text{ mV} \times (2.5 \text{ v/o} \div 5 \text{ v/o})] = 120 \text{ mV}$$

When the span has been set, turn off the span gas flow and remove the calibration adapter from the sensor. Place the lid back on the transmitter enclosure and tighten the cover to insure the enclosure remains watertight. If the ATI receiver alarm relays were inhibited prior to calibration, press the **A/R** switch to return the system to normal operation.

TRANSMITTER FAULT INDICATION

The C12-17 combustible gas transmitter is designed to detect certain fault conditions in the sensor and transmitter and to indicate the fault conditions by driving the 4-20 mA output to below 2 mA. Receiving instruments that can identify this condition and provide a visual indication of the fault will provide added security for your gas detection system. When the C12 signal is used as an input to a PLC or computer system, the system should be programmed to recognize a 2 mA output as a fault condition for the transmitter.

The below 2 mA fault condition will be generated under the following conditions:

One of the sensor leads is not connected at the terminal block.
A sensor wire has broken in the interconnect wiring of a dual conduit installation.
The combustible sensing element has failed.

CALIBRATION FOR OTHER COMBUSTIBLE GASES

As previously mentioned, a combustible gas sensor has a slightly different response to each combustible gas or vapor. In addition, the LEL (Lower Explosive Limit) represents different percent concentrations for different gases. For instance, the LEL for methane is 5% by volume while the LEL for butane is 1.9% by volume. Because of these factors, a combustible transmitter must be adjusted differently if the system is meant to detect a gas or vapor other than methane.

A 1% methane gas standard may still be used for calibration of combustible transmitters when used for other gases. However, the voltage that you set at the transmitter test point will be different for each gas. Table 1 provides the voltage setting for various gases, and the corresponding percent LEL reading for each.

TABLE 1

<u>GAS</u>	<u>VOLTAGE, mV</u>	<u>% LEL</u>
Methane	72	20
Propane	98	36
n-Butane	96	35
n-Pentane	109	43
n-Hexane	127	56
Hydrogen	82	26
Methanol	77	23
Ethanol	83	27
Isopropyl Alcohol	109	43
Acetone	102	39
Methyl Ethyl Ketone	118	49
Benzene	120	50
Toluene	120	50
Acetylene	98	36
Di-ethyl Ether	109	43
Ammonia	67	16
n-Heptane	125	53

SENSOR RESPONSE TEST

While zero and span adjustments are required only periodically, gas sensors should be checked regularly for proper response. The response check can be done quickly by simply aiming the outlet tube from the span gas cylinder at the face of the sensor and turning on the gas flow for 10-20 seconds. The sensor should begin to respond within 5 seconds.

To observe the response at the transmitter, it is necessary to connect a DVM to the test points indicated in Figure 7. If the receiver is nearby, you may simply observe the digital display on the receiver. If the sensor does not respond, it should be replaced.

SENSOR REPLACEMENT

Combustible gas sensors used in the C12 are warranted for 12 months and generally last 5 years or more in the absence of poisoning agents. When sensor replacement is required, it can be done easily and quickly. Open the transmitter and remove the sensor cable from the sensor terminal block on the transmitter module. Unscrew the sensor from the explosion-proof transmitter housing using a wrench on the hex provided on the sensor. Screw in the replacement sensor.

Connect the new sensor to the terminal block (figure 3), on the transmitter board and replace the transmitter cover. After a new sensor has been connected, allow 4 hours for the new sensor to completely stabilize. Then perform a zero and span calibration as described on pages 11 through 13.

DISPLAY & RELAY OPTION

C12-17 transmitters supplied with the display and relay option offer additional features that make operation and calibration somewhat simpler. In addition, the relay allows for local alarm of a high gas condition without the need for wiring back and forth to a remote alarm module.

In normal operation, this version of the C12-17 will continuously display %LEL on the integral liquid crystal display. This display can be used for zeroing and calibration of the transmitter, eliminating the need for a separate DVM as described in the calibration section of this manual.

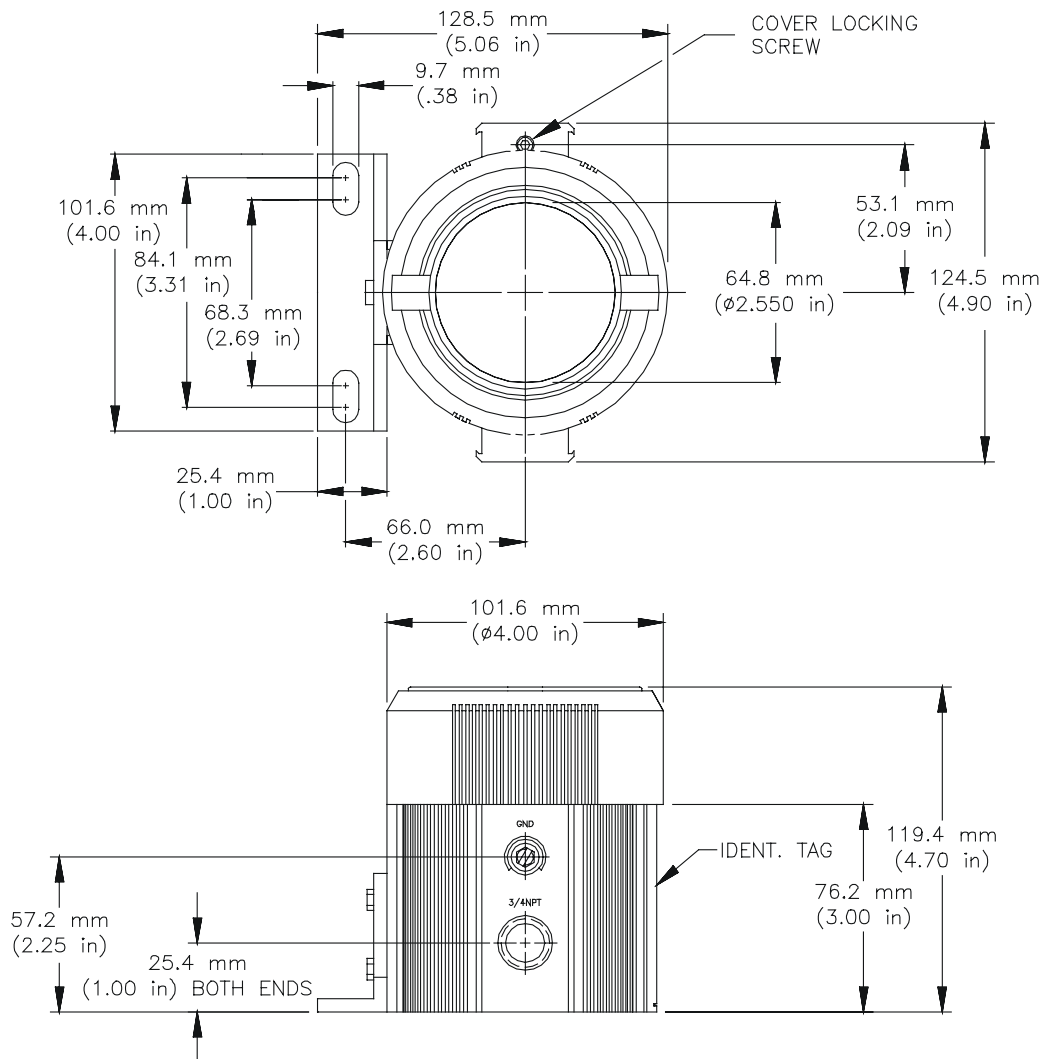

Figure 8 – Enclosure with Display Dimensional Drawing (ATI-0569)

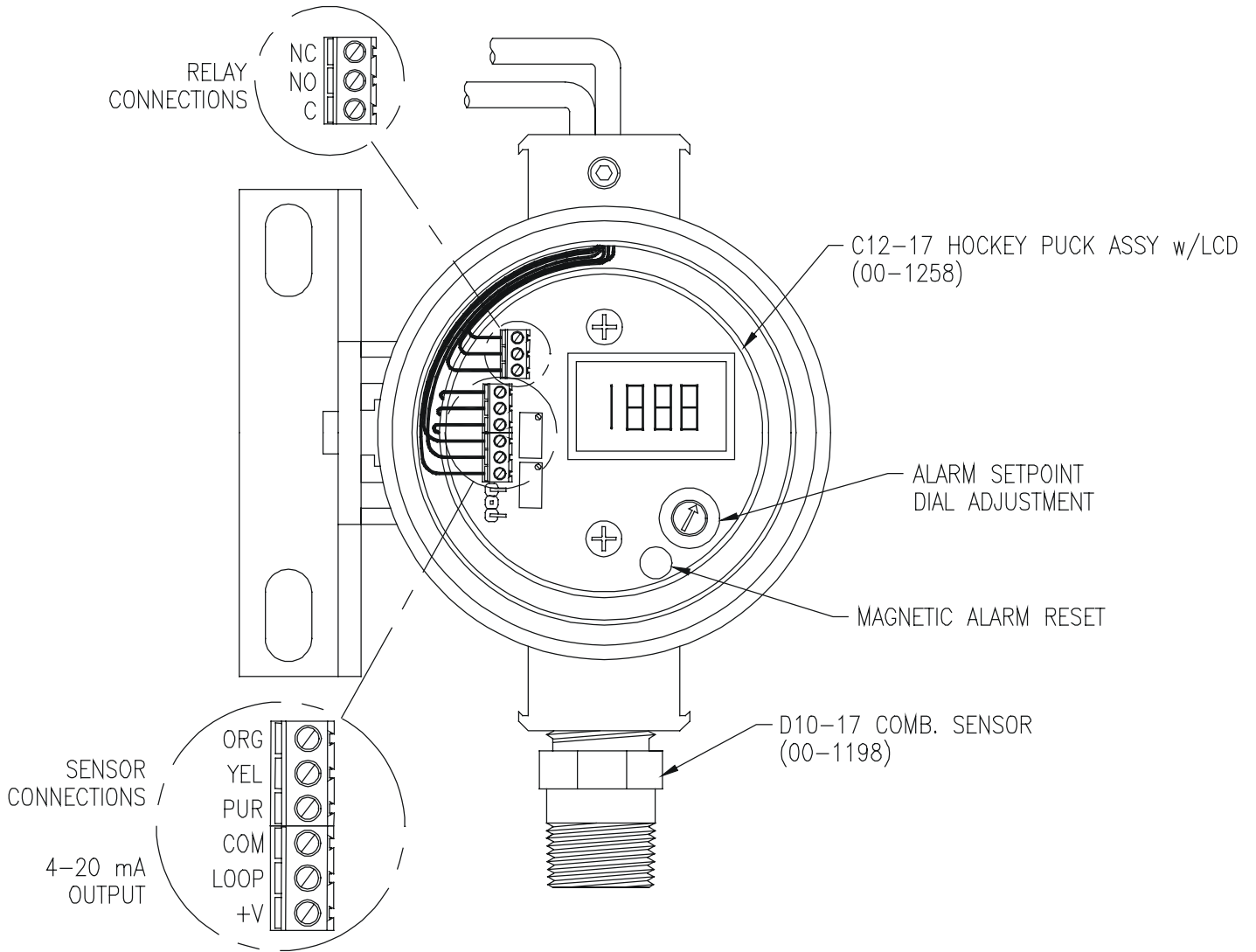

Figure 9 – Transmitter with Display Customer Connections (ATI-0570)

ALARM ADJUSTMENT

Units supplied with the optional display contain a single alarm setpoint and relay which may be used for local alarm functions. The SPDT internal relay is ideal for simple applications where only a local lamp or horn is needed when elevated gas levels are detected.

The alarm setpoint is adjusted using the calibrated dial on the front of the transmitter. The dial is marked 0-100 corresponding to 0-100% LEL. Note that the alarm setpoint cannot be set for a value below 5%. Simply adjust the dial to the desired value and the relay will actuate when the combustible gas level reaches that point. When the relay is activated, a decimal point to the left of the concentration display will indicate that the relay is latched.

The relay is a latching relay and must be reset manually. Reset is done using a magnet through the window of the display. A magnetic screwdriver is supplied with the transmitter for this purpose. If the relay activates and the gas concentration returns to normal, simply hold the magnet on the end of the screwdriver against the yellow dot in the window. The relay will immediately return to a deenergized state. Note that the relay will not reset until the gas concentration is below the setpoint.

TROUBLE FUNCTION

If the internal relay is not to be used for gas concentration alarming, its function can be changed to a trouble relay to provide local indication of a fault condition. If the setpoint is adjusted to "0", the relay will automatically become a trouble relay. If any of the fault conditions described on page 13 occur, the relay will activate. The relay is non-latching and will reset if the fault condition clears.

When transmitter trouble is detected, the LCD display will indicate a "-1" value and the current loop will go to 2 mA. Transmitter operation will return to normal when the trouble condition is corrected.

**C12-17 TRANSMITTER W/O DISPLAY
SPARE PARTS LIST**

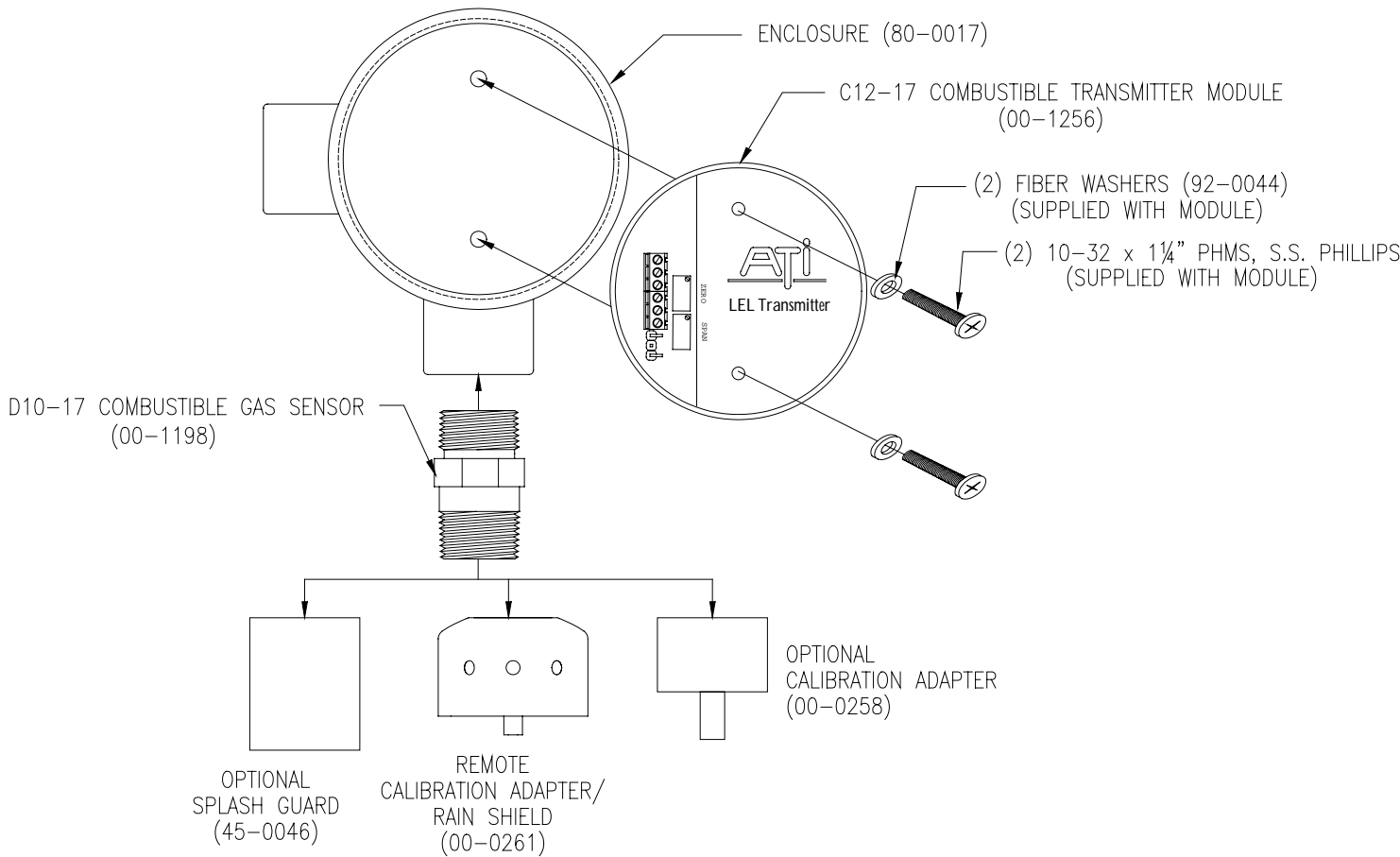

Figure 10 – Standard Combustible Transmitter Exploded View (ATI-0146)

<u>Part Number</u>	<u>Description</u>
00-1256	C12-17 Combustible Transmitter Module
80-0017	Explosion-proof Enclosure
00-1198	D10-17 Combustible Sensor Assembly
92-0043	10-32 x 1 1/4" PHMS, S.S. Phillips
92-0044	Fiber Washer
45-0046	Splash guard
00-0258	Calibration Adapter
00-0261	Remote Calibration Adapter/Rain Shield

**C12-17 TRANSMITTER WITH DISPLAY
SPARE PARTS LIST**

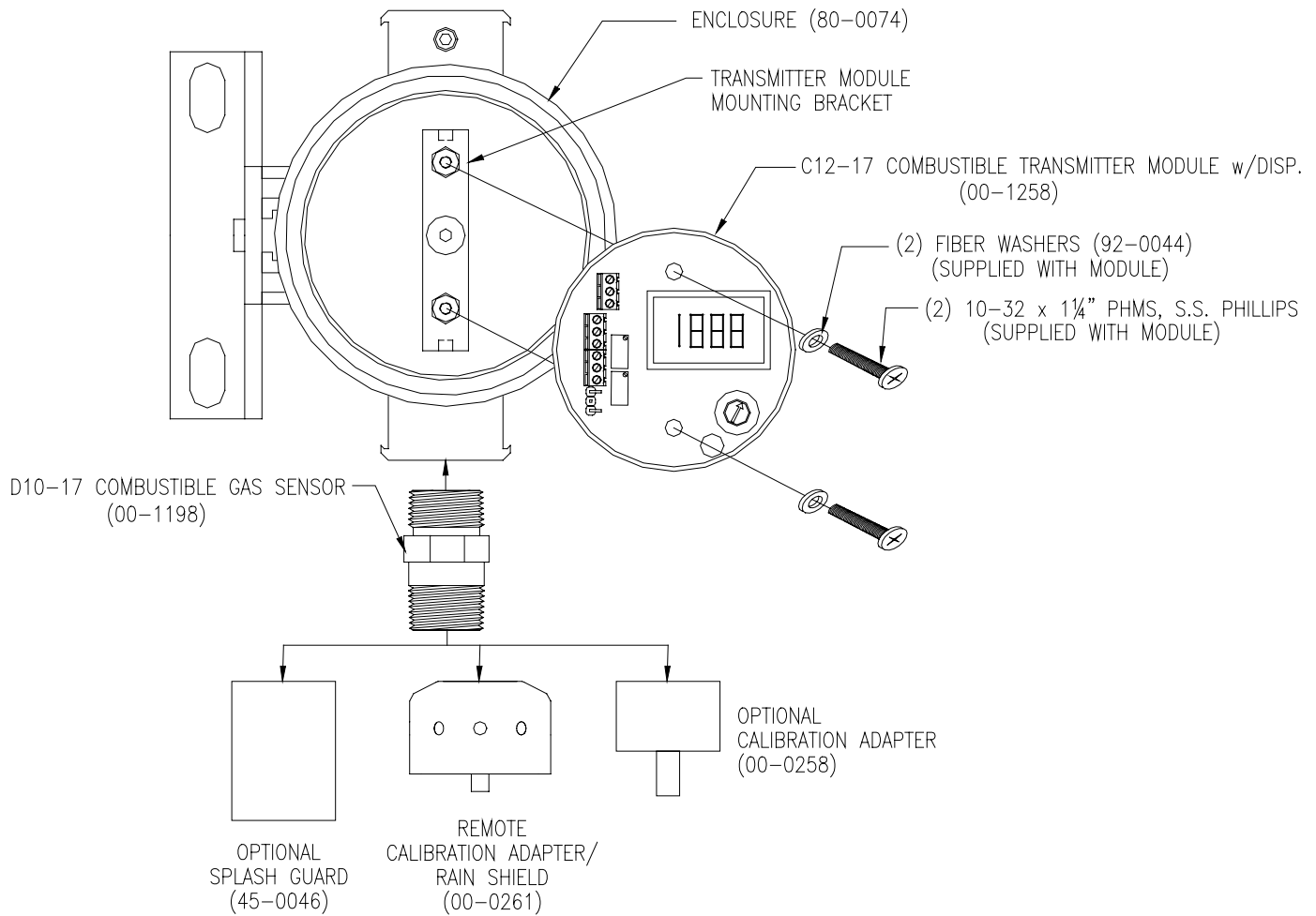

Figure 11 – Standard Combustible Transmitter Exploded View (ATI-0571)

Part Number	Description
00-1258	C12-17 Combustible Transmitter Module with Display
80-0074	Explosion-proof Enclosure for Display Module
00-1198	D10-17 Combustible Sensor Assembly
92-0043	10-32 x 1 1/4" PHMS, S.S. Phillips
92-0044	Fiber Washer
45-0046	Splash Guard
00-0258	Calibration Adapter
00-0261	Remote Calibration Adapter/Rain Shield