

RX Runtime Smart Sensor (S-RTA-M006) Manual



RX Runtime Smart Sensor

S-RTA-M006

Items included:

- Two wire nuts

The RX Runtime (percent on/off and time on/off) Smart Sensor monitors contact closure and is designed to work with HOB0 RX stations only (**it is not compatible with H21, H22-001, or U30 stations**). All sensor parameters are stored inside the smart sensor, which automatically communicates information to the RX station without the need for any programming or extensive user setup.

Specifications

Input Sampling Period	1 second
External Contact Input	Solid state switch closure, logic driven voltage output, or open/closed mechanical switch
Preferred Switch State	Normally open
Solid State Switch Closure	Input Low: < 10 K Ω ; Input High: > 300 K Ω
Logic Signal Level	Logic 0: < 0.4 V DC, Logic 1: > 2.5 V DC
Internal Weak Pull-Up	100 K Ω
Input Range	0 to 3.6 V
User Connection	24 AWG wires, 2 leads: white(+), black(-)
Operating Temperature Range	-40° to 75°C (-40° to 167°F)
Time Accuracy	±4 seconds due to potential clock differences between the sensor and the station. Note that longer logging intervals can result in the maximum error.
Overall Cable Length	6.5 m (21.3 ft.)
Housing Materials	Weatherproof polyamide housing for smart sensor adapter
Length of Smart Sensor Cable*	50 cm (1.6 ft.)
Weight	200 g (7.06 oz)
Number of Data Channels	2
Bits per Sample	12 bits for channel logging runtime as percent 16 bits for channel logging runtime in seconds
Measurement Averaging Option	No

Compliance Marks



The CE marking identifies this product as complying with all relevant directives in the European Union (EU).



The UKCA marking identifies this product as complying with all relevant directives in the UK Declaration of Conformity.

* A single HOB0 RX station can accommodate 15 data channels and up to 100 m (328 ft) of smart sensor cable (the digital communications portion of the sensor cables).

Operation

When connected to an RX station and a third-party sensor or device, this smart sensor checks the state of the switch once every second. At each Logging Interval, one smart sensor channel records how many seconds the switch has been closed and the other channel calculates the percentage of time the switch has been closed.

Note: The first data point logged reports the correct percentage from the time the RX station was configured until the data logging start. The number of seconds reported for the first data point may not represent a full logging interval.

Important: This smart sensor does not support measurement averaging. Do not enable a sampling interval for smart sensors in HOBOLink when configuring the RX station. If you configure your RX station with a sampling interval enabled, then it only logs values for this sensor for the last sampling interval instead of the entire logging interval.

Input Connections

The sensor has two input connections. The white wire (+) is powered at 3.3 V through a 100 kΩ resistor. This power is supplied from the RX station's battery. The black wire (-) is connected through the smart sensor to the RX station's ground connection. Connect the input cable from the smart sensor directly to screw terminals on the third-party sensor or to third-party-sensor cables with the included wire nuts.

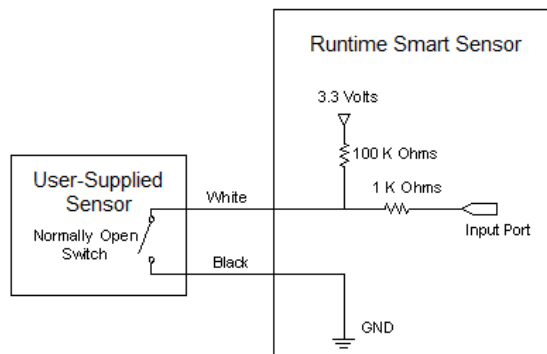

Example Wiring Diagram

When making a connection to a third-party sensor, take time to make sure that the connection is reliable. The connection should be protected from rain, dirt, and direct exposure to the elements. Refer to the documentation for the third-party sensor for additional guidelines.

Connection Using Wire Nuts

Important: If using wire nuts, make sure the connection is protected from the elements.

1. Strip 1 cm (3/8 in.) of insulation from the end of wires, taking care not to nick the metal conductors.
2. Twist the stripped wires together clockwise and then screw on the wire nut clockwise.

3. Check the connection by gently pulling on the wires to verify a solid mechanical connection. Always strain-relief the connection to make sure that the connection is not broken by being jerked or repeatedly worked back and forth.

Connecting the Smart Sensor to an RX Station

Important: Before connecting this smart sensor to an RX station, follow these steps to make sure the station has the latest firmware installed.

1. In HOBOLink, select to Devices and select the tile of your station.
2. In the Device Summary area of the page, look under the Firmware Version. If the Upgrade button appears, then your RX station needs to be upgraded.
3. Tap Upgrade.
4. Press the Connect button on the station to connect to HOBOLink and start the firmware upgrade.
5. Wait for the firmware upgrade to complete. The upgrade icon should be gone in HOBOLink once the upgrade is successful. If the RX station firmware is not successfully installed, it could be because there is an interruption in cellular service or poor signal strength. Contact Onset Technical Support for help.

To connect the smart sensor to an RX station, stop the station from logging and insert the smart sensor's modular jack into an available smart sensor port on the RX station. See the RX station manual for details on operating RX stations with smart sensors.

Mounting

- Secure the smart sensor adapter to the mast with the cable ties as shown. Multiple smart sensor adapters can be stacked as shown in the example below on the right.

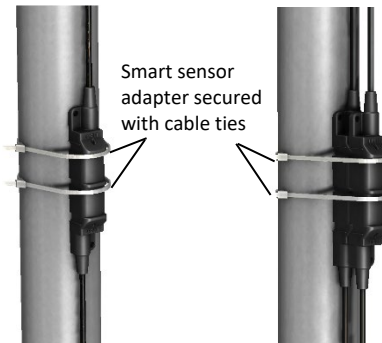

One Smart Sensor Adapter Mounted

Two Smart Sensor Adapters Stacked and Mounted

Alternatively, mount the smart sensor adapter to a flat surface using two screws (no larger than a #6) and two washers as shown.



- The adapter housing should be installed outside the RX station enclosure. Be sure to follow the instructions included with the RX station to ensure that it is properly sealed where the sensor cable exits the station enclosure.
- Secure the adapter housing to the mast or sensor mounting arm. Excess cable should be coiled and secured with cable ties.
- If sensor cables are left on the ground, use a conduit to protect against such things as animals, lawn mowers and exposure to chemicals.

Maximizing Battery Life

The smart sensor consumes about 1 μA of current with the input high (switch open) and about 33 μA with the input low (switch closed). For maximum station battery life, use the smart sensor with switches that are normally open for 90% of the time or longer.