

WARNING: Before driving into the ground, be sure you have underground service clearance to avoid cables, gas lines, pipes, etc.

Component List

- Drive-Point Piezometer Tip
- Screened Extensions
- Extensions (suitable to reach the required depth)
- Couplings (one required for each extension)
- Manual Slide Hammer
- Piezometer tubing (suitable to reach the required depth)
- Drive Head Assembly

Includes: Drive Head, Drive Extension & Tubing Bypass

- Delrin Cap (111148)

Installation with a Manual Slide Hammer

Note: Drive-Points are designed for single use installations (temporary or permanent). They are not meant for removal and reuse.

1. Ensure that all components are clean prior to use.
2. If using piezometer tubing, cut it to the depth of the proposed installation plus an additional 5 ft (1.5 m).
3. If using a 615 or 615S, Connect the 5/8" OD piezometer tubing to barbed fitting on the Drive-Point Piezometer Tip by pushing firmly until the tubing reaches the base of the fitting.

Or, if using a 615C, loosen the compression fitting and insert the 1/4" piezometer tubing. Tighten 1 and 1/4 turns past finger tight to properly secure the tubing in the fitting.

4. Slide a length of extension pipe over the tubing, and thread it firmly onto the Drive-Point Piezometer Tip. Tighten with a pipe wrench.

If using a 615N or 615SN, then you will not be working with tubing. Simply thread the extension pipe onto the Piezometer Tip.

WARNING: When connecting or removing the Tubing Bypass, it is very important to hold the tubing to prevent it from turning. Failure to do so may result in the tube being dislodged from the Drive-Point Tip.

5. Hold the tubing to prevent it from turning, then slide the Tubing Bypass over the tubing and tighten it firmly onto the extension pipe, with the tubing extending through the side hole.
6. Slide the Slide Hammer over the Drive Head and operate the hammer to drive the device until only about 6" (15 cm) of the extension pipe below the Tubing Bypass remains above the ground.

WARNING: For health and safety reasons, it is strongly suggested that only a suitable slide hammer be used for Drive-Point Piezometer installations. Sledge hammers are not suitable and can cause serious physical injury.

7. Remove the hammer, then holding the tubing to prevent it from turning, remove the Drive Head Assembly.
8. Slide a coupling over the tubing and tighten firmly onto the previous extension pipe. Slide the next extension pipe over the tubing and tighten it securely.
9. Repeat steps 5 through 9 until the desired sampling depth is reached.
10. Cut the piezometer tubing to fit flush to the top of the extension pipe. Attach a cap to the top of the piezometer to complete the installation.

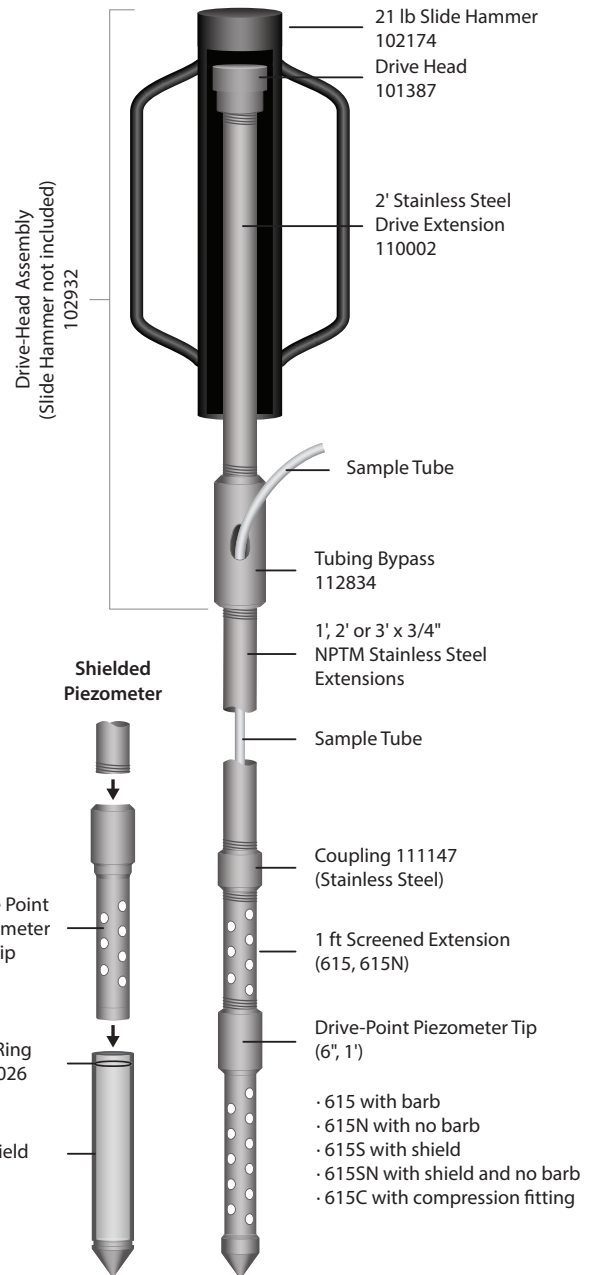

Important Notes about Shielded Piezometers

1. Before driving into the ground, ensure that the shield is on firmly and the o-ring seats properly.
2. Drive the Piezometer an equal length past the desired depth, then pull back/up to expose the inlet.
3. 1ft (102412) and 6" (104370) Replacement Shields are available when re-using the Drive-Point Piezometer.

Continued overleaf...

Monitoring Options

The **615** has a barbed fitting to attach 5/8" x 1/2" LDPE or Teflon tubing. They are suitable for water sampling using Solinst 429 Point-Source Bailers, 404 Inertial Pumps, or the 410 Peristaltic Pump. Water level measurements can be taken using the Model 102 or 102M Water Level Meters.

The **615N** does not have a tubing barb. The open 3/4" (20 mm) piezometer pipe is ideal for water level measurements using the 102 or 102M Water Level Meters, or 101 Water Level Meter, and provides more access to sample with Model 404 Inertial Pumps, or 429 Point-Source Bailers.



The **615S** is a shielded version of the 615. It has the same monitoring options as the standard 615. The shield prevents the screen from smearing during installation in soft soils and clay.

The **615SN** is a shielded version of the 615N. It has the same monitoring options as the standard 615N. The shield prevents the screen from smearing during installation in soft soils and clay.



The **615C** comes with a compression fitting to attach 1/4" x 0.170" LDPE or Teflon tubing. The 615C is suitable for water and soil vapor sampling using the Solinst Model 410 Peristaltic Pump.



1 ft. Screened Extensions are an option for extending the screened length of the piezometer tip. Note: Available with or without a barbed fitting.



1" NPTF to 3/4" NPTM Reducer Coupling Sets (113470) and **1" BSPTF to 3/4" NPTM Reducer Couplings Sets (114259)** are available for installing a Levelogger in a section of 1" extension pipe. See separate installation instructions.



®Solinst is a registered trademark of Solinst Canada Ltd.