



CYCLOPS

SUBMERSIBLE SENSORS

User's Manual



September 05, 2023
P/N 998-2100
Revision 4.0

TURNER DESIGNS
1995 N. 1st Street
San Jose, CA 95112
Phone: (408) 749-0994
FAX: (408) 749-0998

Table of Contents

1. Introduction	
1.1 Description	4
2. Inspection and Setup	
2.1 Instrument Checklist	5
2.2 Housing Configurations	5
2.3 Optional Accessories	6
2.4 Functional Test for Cyclops-7F with connector	7
3. Measurements with the Cyclops-7F	
3.1 Introduction	8
3.2 Setting the Gain	8
3.2.1 Gain Determination Procedure	8
3.2.2 Static Gain Control	9
3.2.3 Auto Gaining	9
3.3 Direct Concentration Calibration	9
3.3.1 Direct Concentration Calibration for Chlorophyll Cyclops-7F	10
3.3.2 Direct Concentration Calibration for Turbidity Cyclops-7F	10
4. Maintenance and Warranty	
4.1 Maintenance	11
4.1.1 Rinsing	11
4.1.2 Care for the bulkhead connector	11
4.1.3 Cleaning the Optics	11
4.2 Warranty Terms	11
4.3 Warranty Service	12
4.4 Out of Warranty Service	12
Appendices	
A Specifications	14
B Recommended Measurement Practices	15
C Wiring Guide	16
D Pigtail Cable and Connector Information	17
E Controlling the Gain	18
F Linear Range, Quenching and Temperature Considerations	19
G Functional Test for Cyclops with no Connector	20
H Using the Cyclops Submersible Sensor with the DataBank	21

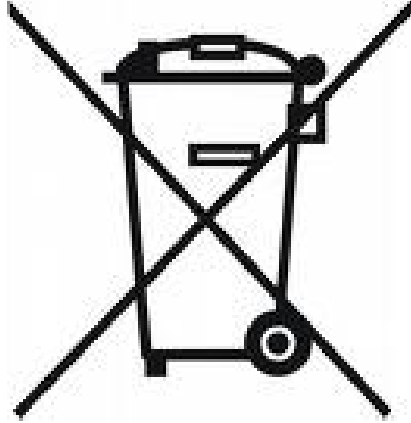

WASTE ELECTRICAL AND ELECTRONIC EQUIPMENT (WEEE) DIRECTIVE

Turner Designs is in the business of designing and selling products that benefit the well-being of our environment. Accordingly, we are concerned with preserving the surroundings wherever our instruments are used and happy to work with customers by complying with the WEEE Directive to reduce the environmental impact resulting from the use of our products.

WEEE Return Process:

To arrange the return of an end-of-life product, proceed as follows:

If you purchased your instrument through a Turner Designs Distributor, please contact your local representative. They will instruct you where to return the end-of-life product.

If you purchased your instrument directly from Turner Designs, please contact Turner Designs Customer Service

By Phone: 1 (877) 316-8049

By Email: Customer Service at support@turnerdesigns.com

Turner Designs will provide a WEEE RMA Number, a Shipping Account Number, and a Ship to Address. Package and ship the product back to Turner Designs.

The product will be dealt with per Turner Designs' end-of-life recycling program in an environmentally friendly way.

Cyclops-7F Submersible Sensor

1. Introduction

1.1 Description

The Turner Designs Cyclops-7F Submersible Sensor is an accurate single-channel detector that can be used for many different applications. It is designed for integration into multi-parameter systems from which it receives power and delivers a voltage output proportional to the concentration of the fluorophore, particle, or compound of interest.

The Cyclops voltage output can be correlated to concentration values by calibrating with a standard of known concentration.

Cyclops-7F Submersible Sensor

2. Inspection and Setup

2.1 Instrument Checklist

The Cyclops-7F Submersible Sensor shipment package consists of:

- Cyclops-7F Submersible Sensor:
Configured and factory scaled for the specified analysis (see Identification Letter stamped on the connector for specified analysis):
 - “C” = Chlorophyll
 - “R” = Rhodamine
 - “F” = Fluorescein
 - “P” = Phycocyanin
 - “U” = CDOM / FDOM
 - “G” = Refined Fuels
 - “T” = Turbidity

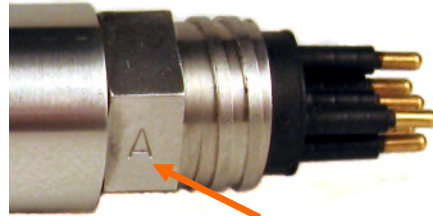

- Test Criteria

2.2 Housing Configurations:

- Stainless Steel Cyclops-7F (P/N: 2110-000- “Identification Letter”)
- No Connector Cyclops-7F (P/N: 2110-000- “Identification Letter”-NC).
Refer to Appendix G for wiring and functional testing.

2.3 Optional Accessories include:

- Cyclops-7F Pigtail Cables with Locking Sleeve (see Appendix D for more information)
 - 0.6 meter Pigtail Cable with Locking Sleeve (P/N 2100-750)
 - 10 meter Pigtail Cable with Locking Sleeve (P/N 2100-751)



Note: Turner Designs recommends you do NOT tow sensors with cables.

- DataBank Handheld Data Logger (see Appendix H)
- Flow Cap (see Accessory Instructions on USB Flash Drive)
 - Cyclops-7F Stainless Steel (P/N 2100-600)
- Shade Cap (see Accessory Instructions on USB Flash Drive)
Note: We recommend use of the shade cap as it provides a fixed distance for sample measurement and minimizes effects from ambient light.
 - Cyclops-7F Stainless Steel (P/N 2100-701)
- Solid Secondary Standard (SSS) for *in vivo* Chlorophyll, Rhodamine, Phycocyanin, and Fluorescein (see Accessory Instructions on USB Flash Drive)
 - Cyclops-7F Stainless Steel (P/N 2100-900)

Cyclops-7F Submersible Sensor

- Solid Secondary Standard (SSS) for UV Sensors (CDOM / FDOM and Refined Fuels) (see *Accessory Instructions on USB Flash Drive*)
 - Cyclops-7F Stainless Steel (P/N 2100-904)



Shade Cap



Solid Secondary Standard



Flow Cap

Cyclops-7F Submersible Sensor

2.4 Functional Test for Cyclops-7F with connector

To perform a functional check on the Cyclops-7F, connect the Pigtail colored wires to the power supply and multi-meter as shown in Figure 1 below.

Additional Equipment required for functional tests:

DC Power Supply, 3 - 15 VDC, >100 mA

Multi-meter to read 0 – 5 VDC



Note: Supply voltages greater than 15 VDC will result in damage to the sensor.

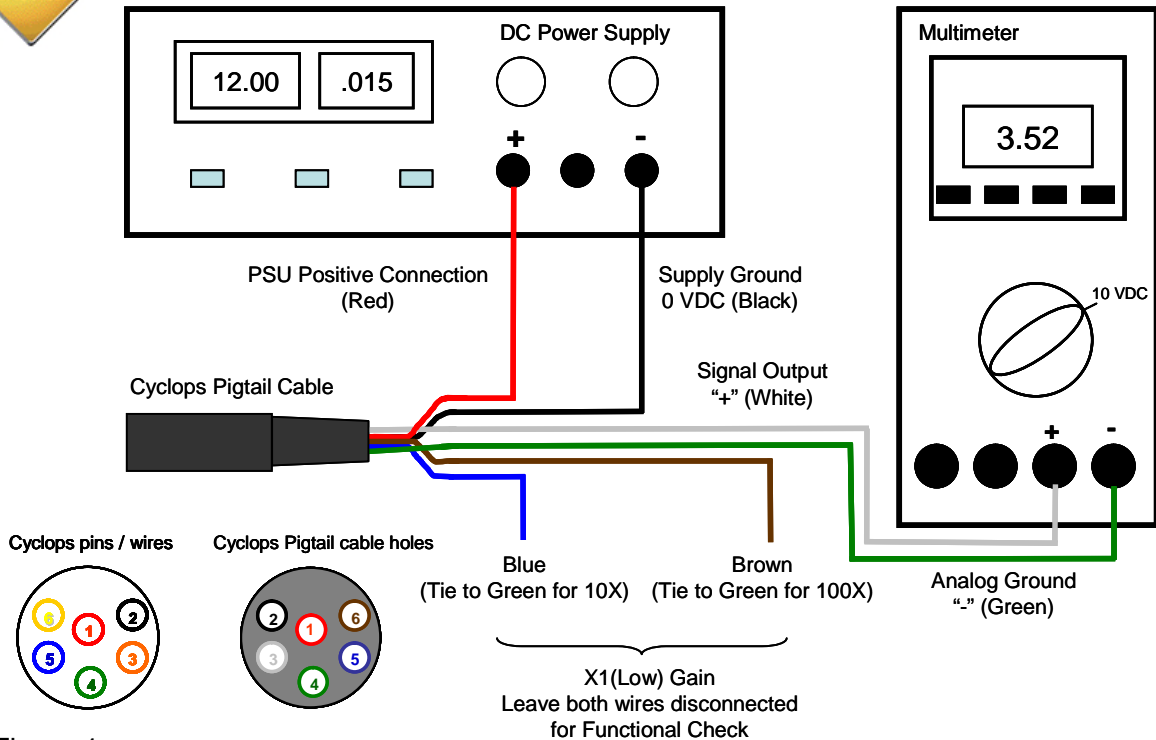

Figure 1.

With the Cyclops connected as shown in Figure 1 answer questions 1-3 by making the following functional tests:

1. Is the LED on?
Hold a piece of white paper about $\frac{1}{2}$ an inch in-front of the optical head to ensure the LED is on. **Note: Cannot perform this test for Turbidity sensors because they use IR which is not visible.**
2. Is there voltage output?
The multi-meter should be reading some voltage >0 VDC
3. Does the voltage output change?
Move the light source closer to your hand or a surface and check if the voltage output increases.

Cyclops-7F Submersible Sensor

3. Measurements with the Cyclops-7F

3.1 Introduction

The following information will describe how to:

- Determine and set the appropriate gain
- Calibrate the Cyclops-7F using standards with known concentrations
- Make measurements with the Cyclops-7F
- Use the Solid Secondary Standard

Note: It is important to keep the sensor clean for accurate measurements; see section 4.1 for information on cleaning your sensor.

3.2 Setting the Gain

Gain setting refers to the sensitivity configuration of the sensor. There are three gain settings: X1, X10 and X100. As the gain increases, the sensitivity increases and the concentration range decreases.

3.2.1 Gain Determination Procedure

- 1) For *in vivo* applications, take a natural sample of water from a sampling station where you plan to deploy the Cyclops-7F. Applying good measurement practices, store it properly and quickly transport it to a laboratory where you have the Cyclops connected to a multi meter and DC power source (see *Figure 1*).
- 2) Pour the water sample into a clean darkened beaker and submerge the optical end of the Cyclops (see *Appendix B for "Recommended Measurement Practices for using your Cyclops in the Lab" for how best to accomplish these steps*).
- 3) Activate the X10 gain setting (see *Wiring Guide Appendix C*) if you believe the sample to represent a typical condition. You would like to obtain a signal from the sample that is significantly higher than a blank sample (de-ionized water or filtered seawater), but not a signal that is close to the maximum of 5 Volts.
- 4) If the sample signal is high, (>3.0 V for example) you may choose to use the X1 gain instead of the X10 gain setting so that you avoid going over scale once you deploy the Cyclops.
- 5) If the sample signal is exceptionally low (<0.3V) you may choose to use the X100 gain setting to achieve higher sensitivity but a smaller measurable range

This process is easier for dye tracing applications. Simply create the dye dilution of interest and record what signal level it provides on the three gain settings.

3.2.2 Static Gain Control

Cyclops-7F Submersible Sensor

If integrating into a multi parameter system or data logger that is set up for “Static Gain Control”, which refers to the use of only one gain setting at a time, then you must determine which gain to use prior to deployment (see section 3.2.1) and have an integration cable made to activate that specific gain (see *Appendix C*). For most applications, the X10 gain will provide the best sensitivity, range, and resolution.

Customers wanting to dynamically change the gain ranges to achieve the optimum operating range should refer to “Method 2 – Dynamic Gain Control” in *Appendix E* on how to interface with a Data Collection System with programmable outputs.

3.2.3 Auto Gaining

Certain data loggers or multi parameter systems will have an auto gaining feature which will automatically adjust the sensitivity according to the voltage output from the Cyclops sensor. This feature maximizes the performance of Cyclops sensors allowing users to detect a broad range of concentrations, obtain the best resolution, and read minimum detection limits without having to rewire or manually change the sensor’s sensitivity. Turner Designs manufactures the DataBank Handheld Data Logger (see *Appendix H*) which has the auto gain feature and other functions that maximize the performance of Cyclops sensors.

3.3 Direct Concentration Calibration

The Cyclops-7F can be calibrated using a liquid calibration standard which correlates the standard’s known concentration to the voltage measured for that specific standard:

- 1) Connect the Cyclops-7F to a power source and set the Cyclops-7F to a gain setting (see section 3.2.1 for explanation on how to determine gain)
- 2) Measure the voltage from a blank sample for the configured gain setting.
Note: A good blank to use for this application is deionized water.
- 3) Use a standard of known concentration and create a correlation between the standard’s concentration and the sensor’s voltage response. Turner Designs offers liquid dye standards which can be used for Direct Concentration Calibration converting relative fluorescence to concentration estimates. The response from various dye standards is correlated with actual fluorophore concentrations for many applications. Calibrate using the following data table to obtain fluorophore concentration estimates.
- 4) Once calibrated to a known concentration with correlation. Use a solid standard if available and adjust to have a response similar to the liquid standard correlation. This will become a reference unit to instantly view if the Cyclops-7F has drifted from the calibration or if the liquid calibration solution is at fault. The reference solid standard is not a calibration device.

Cyclops-7F Submersible Sensor

Application (Channel)	Liquid Calibration Standard Concentration (ppb)	Part Number	Fluorophore Concentration	Fluorophore	NOTES
Chl <i>in vivo</i> (Blue)	RWT 400 ppb	6500-120	40 µg/L	CHL	
Phycocyanin (PC)	RWT 200 ppb	6500-020	260 ppb	PC	
CDOM	PTSA 400 ppb	10-609	125 ppb	Quinine Sulfate	
Fluorescein	10 ppb 100 ppb 400 ppb	10-508 10-506 10-509	100 ppb	Fluorescein	
Other recommended standards:					
Turbidity	10 NTU 100 NTU 1000 NTU	8506 8507 8620	10 NTU 100 NTU 1000 NTU	Turbidity	AMCO Clear standards can be purchased through: GFS Chemicals
Refined Fuels	CAS# 76758-30-0 4500 ppb NDSA is equivalent to 1 pm BTEX				

Note: *These fluorophore concentrations are an approximation. Actual estimates will vary depending on specific sampling conditions.*

- 5) Once a correlation has been made, use the following equation to calculate concentration estimates for the calibrated gain:

$$C_{\text{Sample}} = [(C_{\text{Std}}) / (\text{Volts}_{\text{Std}} - \text{Volts}_{\text{Blank}})] * (\text{Volts}_{\text{Sample}} - \text{Volts}_{\text{Blank}})$$

C_{Std} = Concentration value of standard used for calibration

C_{sample} = Concentration of sample

$\text{Volts}_{\text{Std}}$ = Voltage reading from standard concentration

$\text{Volts}_{\text{Sample}}$ = Voltage reading from sample(s)

$\text{Volts}_{\text{Blank}}$ = Voltage reading from blank

Cyclops-7F Submersible Sensor

4. Maintenance and Warranty

4.1 Maintenance

4.1.1 Rinsing

The Cyclops-7F should be rinsed in fresh water following each deployment, ideally until it is completely clean again. Wipe clean with non-abrasive cloth, such as microfiber or cotton.

4.1.2 Care for the bulkhead connector

A light coat of Silicone spray should be used on the rubber of the male pins of the bulkhead to aid in sealing. The manufacturer recommends 3M™ Silicone Lubricant Spray or Loctite 8021 spray. **Note: You should avoid using silicone grease. Do NOT use WD-40, it will destroy the connectors.**

4.1.3 Care for the optics

The optical window should be visually inspected after each deployment following a rinsing in fresh water. If extra cleaning is needed, use optical tissue to clean the window with soapy water.



Note: The Cyclops-7F should NOT come in contact with any organic solvents (i.e., acetone, methanol) or strong acids and bases.

The UV Cyclops models are the **ONLY** Cyclops sensors that can be calibrated with Quinine Sulfate standards made in Hydrosulfuric Acid. All other Cyclops models **CANNOT** be used in Hydrosulfuric Acid.

4.2 Terms

Turner Designs warrants the Cyclops-7F and accessories to be free from defects in materials and workmanship under normal use and service for a period of 12 months from the date of shipment from Turner Designs with the following restrictions:

- Turner Designs is not responsible for replacing parts damaged by accident or neglect. Your instrument must be installed according to instructions in the User's Manual. Damage from corrosion is not covered. Damage caused by customer modification of the instrument is not covered.
- This warranty covers only Turner Designs products and is not extended to equipment used with our products. We are not responsible for incidental or consequential damages, except in those states where this

Cyclops-7F Submersible Sensor

limitation is not allowed. This warranty gives you specific legal rights and you may have other rights which vary from state to state.

- Damage incurred in shipping is not covered.

4.3 Warranty Service

To obtain service during the warranty period, the owner shall take the following steps:

1. Write, email or call Turner Designs Technical Support and describe as precisely as possible the nature of the problem.

Phone: 1 (877) 316-8049

Email: support@turnerdesigns.com

2. Carry out any adjustments or tests as suggested by Technical Support.
3. If proper performance is not obtained you will be issued a Return Materials Authorization number (RMA) to reference. Package the unit, write the RMA number on the outside of the shipping carton, and ship the instrument, prepaid, to Turner Designs. If the failure is covered under the warranty terms the instrument will be repaired and returned free of charge, for all customers in the contiguous continental United States.

For customers outside of the contiguous continental United States who purchased equipment from one of our authorized distributors, contact the distributor. If you purchased directly, contact us. We will repair the instrument at no charge. Customer pays for shipping, duties, and documentation to Turner Designs. Turner Designs pays for return shipment (custom duties, taxes and fees are the responsibility of the customer).

4.4 Out-of-Warranty Service

Follow steps for Warranty Service as listed above. If Technical Support can assist you by phone or correspondence, we will be glad to, at no charge. Repair service will be billed on a fixed price basis, plus any applicable duties and/or taxes. Shipment to Turner Designs should be prepaid. Your bill will include return shipment freight charges.

Address for Shipment:

Turner Designs, Inc.
1995 N. 1st Street
San Jose, CA 95112

Cyclops-7F Submersible Sensor

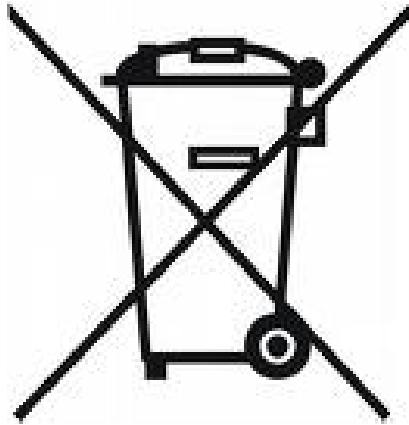

Cyclops-7F Submersible Sensor

Appendix A: Specifications

Parameter	Specification																
Linearity (full range)	0.99 R ²																
Power Requirement mW @ 12V	<table border="1" style="width: 100%; border-collapse: collapse;"> <tr> <td>CDOM/FDOM</td> <td>240</td> <td>Phycocyanin</td> <td>160</td> </tr> <tr> <td>Chlorophyll <i>in vivo</i></td> <td>240</td> <td>Rhodamine Dye</td> <td>175</td> </tr> <tr> <td>Fluorescein Dye</td> <td>145</td> <td>Turbidity</td> <td>120</td> </tr> <tr> <td>Oil - Fine</td> <td>530</td> <td></td> <td></td> </tr> </table>	CDOM/FDOM	240	Phycocyanin	160	Chlorophyll <i>in vivo</i>	240	Rhodamine Dye	175	Fluorescein Dye	145	Turbidity	120	Oil - Fine	530		
	CDOM/FDOM	240	Phycocyanin	160													
	Chlorophyll <i>in vivo</i>	240	Rhodamine Dye	175													
	Fluorescein Dye	145	Turbidity	120													
Oil - Fine	530																
Input Voltage	3 – 15 VDC																
Signal Output	0 – 5 VDC Analog																
Temperature Range	Ambient: 0 to 50 °C Water Temp: -2 to +50 °C																
Light Source	Light Emitting Diode																
Excitation Wavelength	Visible – Chl, RWT, PC, PE, F UV – CDOM / FDOM, Oil, OB, RF, PTSA IR – Turbidity																
Detector	Photodiode																
Detection Wavelength	300 – 1100 nm																
Warm up time	Cyclops-7F: 1 second																
Housing Material – Cyclops-7F	316 Stainless Steel																
Dimensions – Cyclops-7F	Stainless Steel L: 5.74 in., 14.48 cm; L NC: 4.34 in., 11.02cm D: 0.875 in., 2.23 cm																
Depth Rating – Cyclops-7F	600 meters																
Weight – Cyclops-7F	5 oz; 142 gm																

Cyclops-7F Submersible Sensor

Appendix B: Recommended Measurement Practices

Recommended Lab Practices for Measurements

The following steps will improve the accuracy and repeatability of your measurements, especially at low concentration levels:

1. Use a non-fluorescent container for your water samples. Such as a glass beaker wrapped in black electrical tape. **Note: Plastic may fluoresce and interfere with the sample's fluorescence.**
2. If using a glass container, place the container on a non-reflective black surface.
3. Ensure that the sensor is more than 3 inches above the bottom of the container.
4. Ensure that the sensor is in the center of the container and has more than 2 inches clearance between the circumference of the sensor and the inside surface of the beaker.

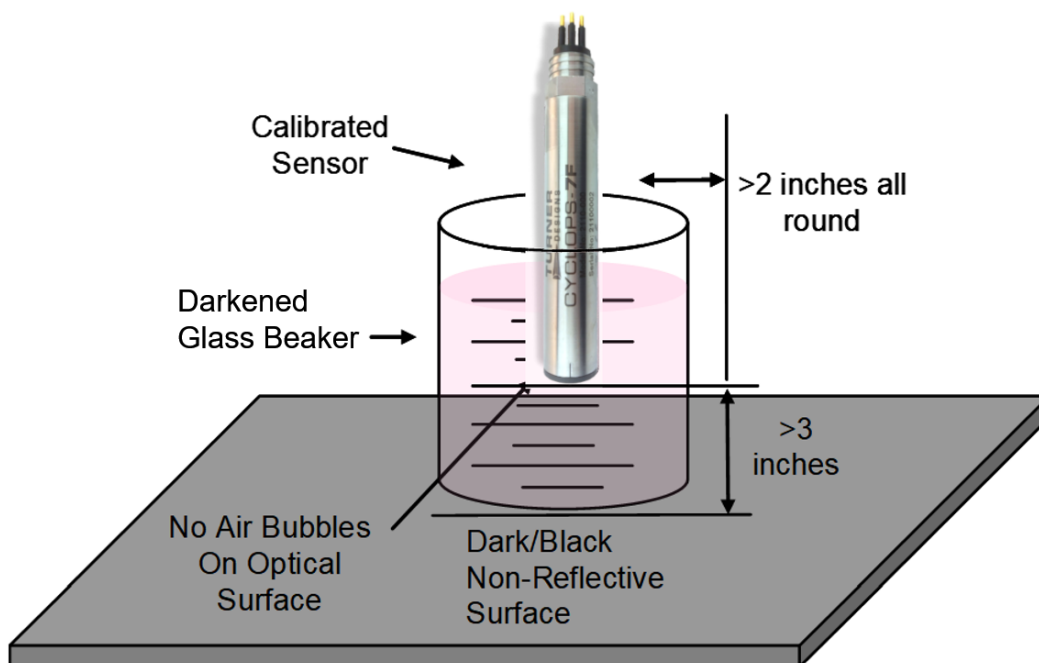

Cyclops-7F Submersible Sensor

Appendix C: Wiring Guide

Cyclops Wire	Pin Number	Function	Connection
Red	1	Supply Voltage 3 – 15 VDC	PSU – Positive Connection
Black	2	Supply Ground, 0VDC	PSU – Ground Connection
Orange	3	Signal Out to data logger “+” 0 – 5VDC	Multimeter Positive Connection
Green	4	Analog Ground “-,” 0 VDC	Multimeter Negative Connection
Blue	5	X10 Gain, (Medium Sensitivity)	See table below
Yellow	6	X100 Gain, (High Sensitivity)	See table below

Gain Switching Table

Gain 10 (Blue)	Gain 100 (Brown)	Gain
Not connected	Not connected	X 1
Connected to analog ground	Not connected	X 10
Not connected	Connected to analog ground	X 100

Cyclops-7F Submersible Sensor

Appendix D: Pigtail Cable and Connector Information

Dimension details of 24" length cable with 20 gauge colored lead wire, connects to 6 pin male connector. (Cable manufacturer/Part No: IMPULSE/MCIL-6-FS)

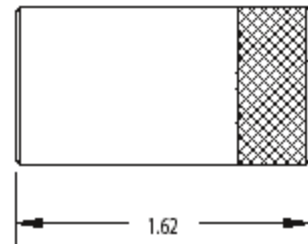
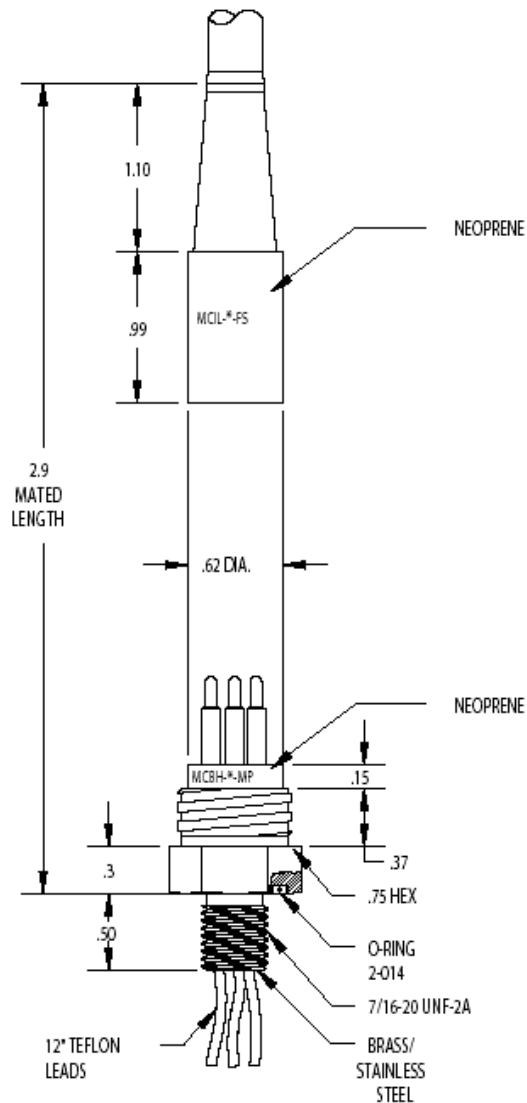

*Female locking sleeve,
(Impulse P/No. MCDLS-F)*

Cyclops Pigtail cable holes

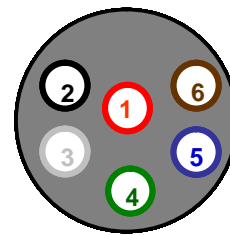

Cyclops pins / wires

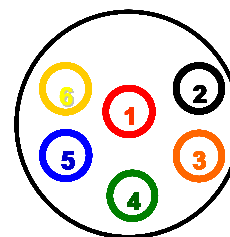

A maximum cable length up to 100 meters can be connected to the Cyclops if the following conditions are met:

- 1) The cable is shielded and contains 20 gauge conductor size or greater (i.e. Beldon No. 8426 cable).
- 2) The 0-5 volt Analog output is connected to a device (i.e. Data Logger) with an input impedance of 1 MegOhm or greater.
- 3) The supply Voltage to the Cyclops is between 5 and 15 volts.

Cyclops-7F Submersible Sensor

Appendix E: Controlling the Gain

The operating range can either be set to one of the 3 available ranges, which will be referred to as "Static Gain Control", or it can be dynamically changed to achieve the optimum operating range, referred to below as "Dynamic Gain Control". The first approach is applicable when using the Cyclops-7F as a stand-alone sensor. The second approach is applicable when the Cyclops-7F is integrated into a system with control capability.

Both methods are implemented by grounding "driving Low" the appropriate gain control pin. The X10 and X100 gain control pins are normally in a "High" state if they are not connected to anything. This means the Cyclops default is the X1 gain (largest concentration range) mode. The Cyclops can be put into higher gain, lower concentration range modes, by connecting either the X10 or X100 pin (**but not at the same time**) to ground.

Method 1 - Static Gain Control

Connect the X10 or X100 pin to the analog ground pin of the Cyclops pigtail connector. See the Gain Switching Table in Appendix C to determine the required configuration for desired gain/measurement range. See Appendix D for Pigtail Cable and Connector information. Also, see "Setting the Gain" section 3.2 for more information on "Static Gain Control."

Method 2 - Dynamic Gain Control

If you have a Data Collection System (DCS) that has programmable outputs, you can use them to control the Cyclops gain settings. Following are three common output types found in DCSs and how to connect them to the Cyclops. Refer to your DCS manual to determine which is appropriate. (For those who want technical data: the Cyclops's X10 and X100 gain control pins are connected internally to the input of a Schmitt trigger inverter, part number 74LVC1G14, and a 100K ohm pull-up resistor. Both use a 5-Volt power supply.)

Output type 1: Digital Signals

Logic signals can be used to drive the gain control pins. In most cases you can connect the digital signal output of the DCS directly to the Cyclops gain control pins. To drive them high, the voltage should be 3 VDC min – 5 VDC max. To drive them low, the voltage should be 1 VDC max – 0 VDC min. You may need to connect the Cyclops analog ground to the DCS ground.

Output type 2: Open Collector Signals

This type of output is either open or connected to ground. Connect the Cyclops gain control pins directly to these outputs. You may need to connect the Cyclops analog ground to the DCS ground.

Output type 3: Relays

Relays act as a controllable switch. Connect one end of the relay to the Cyclops analog ground. Connect the other end of the relay to the Cyclops gain control pin.

Cyclops-7F Submersible Sensor

Appendix F: Linear Range, Quenching and Temperature Considerations

The linear range is the concentration range in which the fluorometer's output is directly proportional to the concentration of the signal. The linear range begins with the smallest detectable concentration and spans to an upper limit (concentration) that is dependent upon the properties of the material, filters used, and path length.

A non-linear relationship is seen at very high concentrations where the signal does not increase at a constant rate in comparison to the change in concentration (see figure below). At even higher concentrations, the signal will decrease even though the sample concentrations are continuing to increase. This effect is known as "signal quenching."

Linearity can be checked by diluting a sample 1:1 or some other convenient ratio. If the sample is still in the linear range, the reading will decrease in direct proportion to the dilution. If the reading does not decrease in direct proportion to the dilution, or if the reading increases, the sample is beyond the linear range.

Temperature Considerations

Fluorescence is temperature sensitive. As the temperature of the sample increases, the fluorescence decreases. For greater accuracy, record the sample temperature and correct the sensor output for changes in temperature.

For further information on how temperature, light, water quality and the physiological state of the algal cells can all affect the measurement of chlorophyll, please refer to the application section of Turner Designs' website.

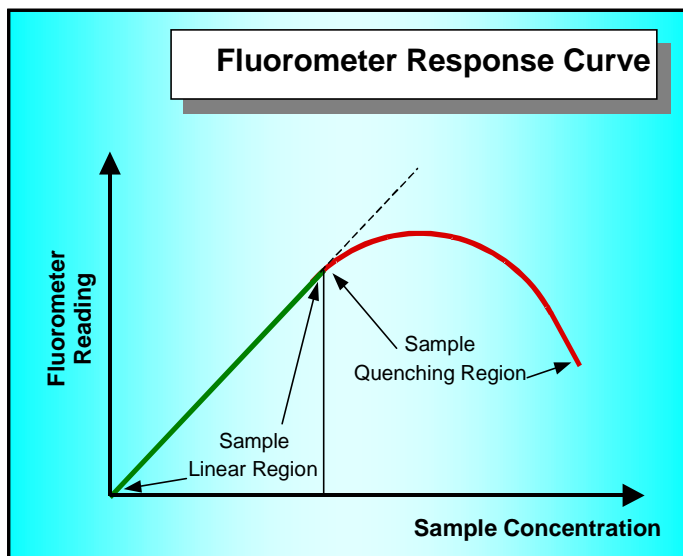

Graph showing Linear and Quenching Regions of the sample's response

Cyclops-7F Submersible Sensor

Appendix G: Functional Test for Cyclops with no Connector

To perform a functional check on the Cyclops, connect the Cyclops colored wires to the power supply and multi-meter as shown in Figure 2 below.



No Connector Cyclops (P/N: 2110/2100-000- "Identification Letter"-NC)

Additional Equipment required for functional tests:
DC Power Supply, 3 - 15 VDC, >100 mA
Multi-meter to read 0 – 5 VDC



Note: Supply voltages greater than 15 VDC will result in damage to the sensor.

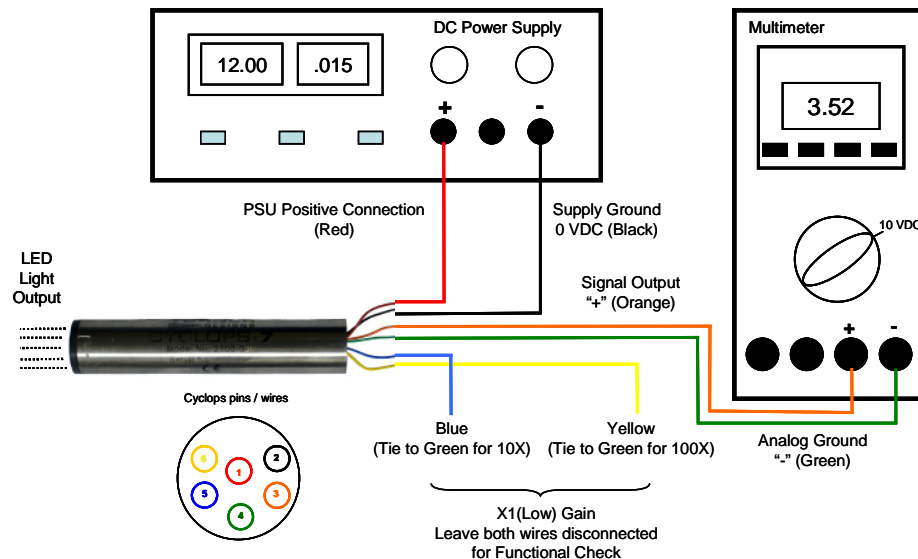

Figure 2.

With the Cyclops connected as shown in Figure 2 answer questions 1-3 by making the following functional tests:

1. Is the LED on?
Hold a piece of white paper about $\frac{1}{2}$ an inch in-front of the optical head to ensure the LED is on. **Note: Cannot perform this test for Turbidity sensors because they use IR which is not visible.**
2. Is there voltage output?
The multi-meter should be reading some voltage >0 VDC
3. Does the voltage output change?
Move the light source closer to your hand or a surface and check if the voltage output increases.

Cyclops-7F Submersible Sensor

Appendix H: Using the Cyclops Submersible Sensor with the DataBank

Cyclops sensors are analog output devices that produce a 0 – 5 volt signal that is proportional to the fluorophore being measured. Turner Designs offers the DataBank, a universal handheld meter, datalogger, and power supply that can be used to maximize performance of Cyclops sensors with functions such as:

- Auto gaining
- User defined calibrations
- Large internal memory
- Interval logging

The DataBank comes with intuitive GUI software that allows users to easily calibrate, set up logging, download data, and define parameters and values necessary to help configure the Cyclops for a specific application or study. Available options include GPS capability, external power, travel case, and car charger.



DataBank uses for different sampling protocols:

Multiple Site Measurements – measure fluorescence at various locations within your water system or across many systems; GPS enabled units provide latitude/longitude data per location.

Profiling – purchase extended cables to allow for vertical profiling.

Monitoring – deploy the Cyclops to a fixed location or depth and monitor the signal over time; set up logging to capture a signal within a specific time frame; download data while the sensor is deployed and continuously measuring; set up digital data output via HyperTerminal.

For any application or sampling protocol, the DataBank facilitates and maximizes performance of all Cyclops sensors allowing versatility and flexibility in calibration, setup, and measurement.

Connecting the Cyclops to Turner Designs' DataBank:

Simply connect the bare wires from the Cyclops's pigtail to the DataBank board as shown below and move the switch to select **dV**.

